



ASTR/PHYS 1060: The Universe

Chapter 3: Laws of Motion

!!!!!! IMPORTANT !!!!!

Use the correct
website, which has
“astro” & “2019”
in the URL

!!!!!! IMPORTANT !!!!!

New Reading Assignment (Ch. 4) to be completed in Canvas
due on Thursday, September 5th (not yet posted)

HW1 posted to website under:

[http://www.astro.utah.edu/~wik/courses/astr1060fall2019/
homework.html](http://www.astro.utah.edu/~wik/courses/astr1060fall2019/homework.html)

due on Thursday, September 5th

First, some bad news...

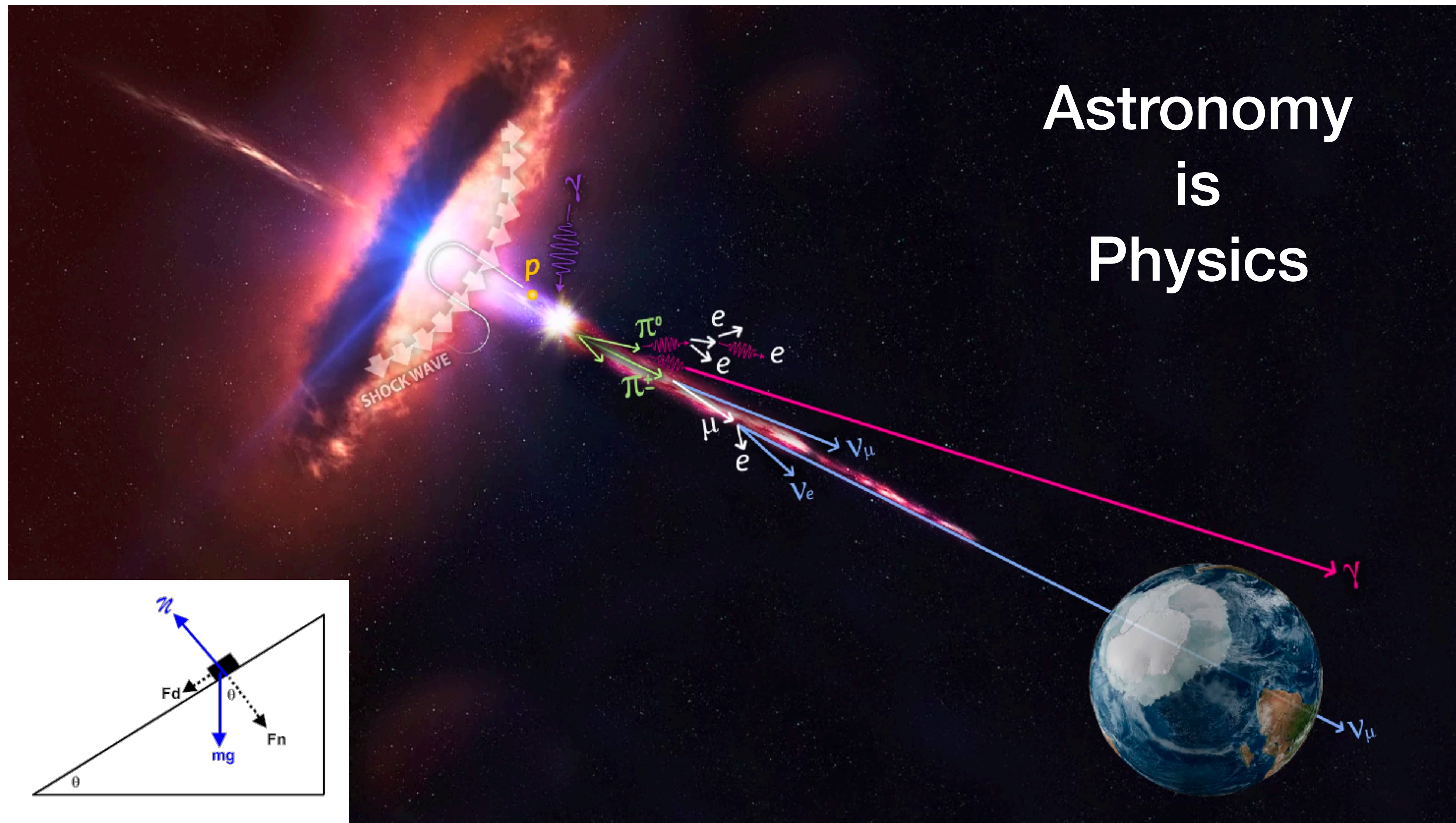

Astronomy
is
Physics

Physics began by explaining astronomical observations

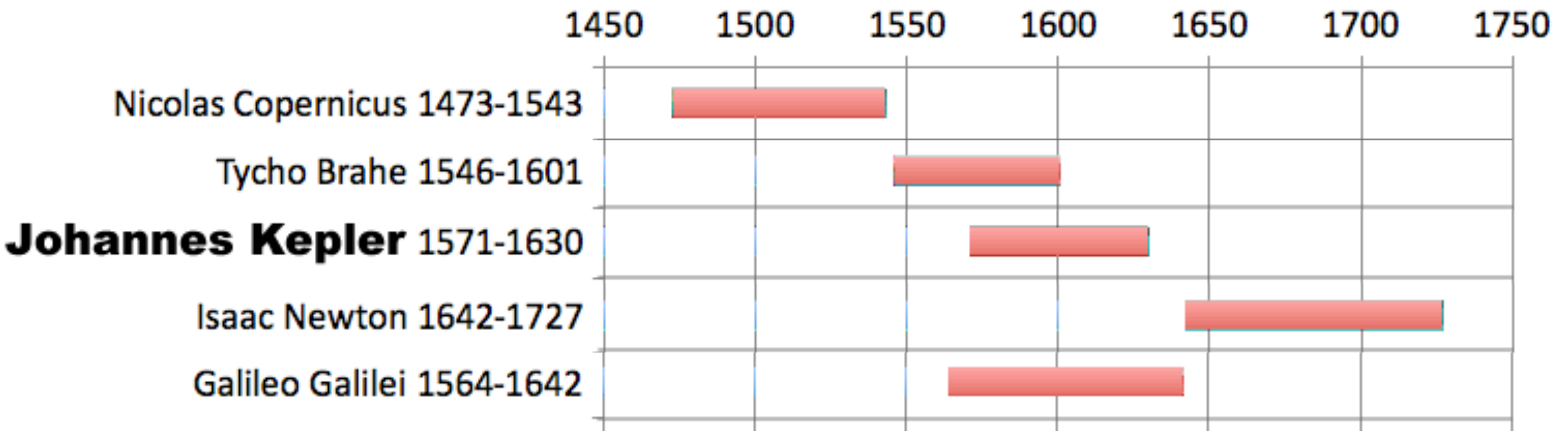

Goal: predict the motions of the planets against the “fixed stars”



Motion was not simple

Models were built to explain them, and did OK — but discrepancies remained

The lack of perfect agreement implied the “true” description of planetary motion was still up for grabs

Epicycle Mania! Everything must move in circles, the perfectest of shapes

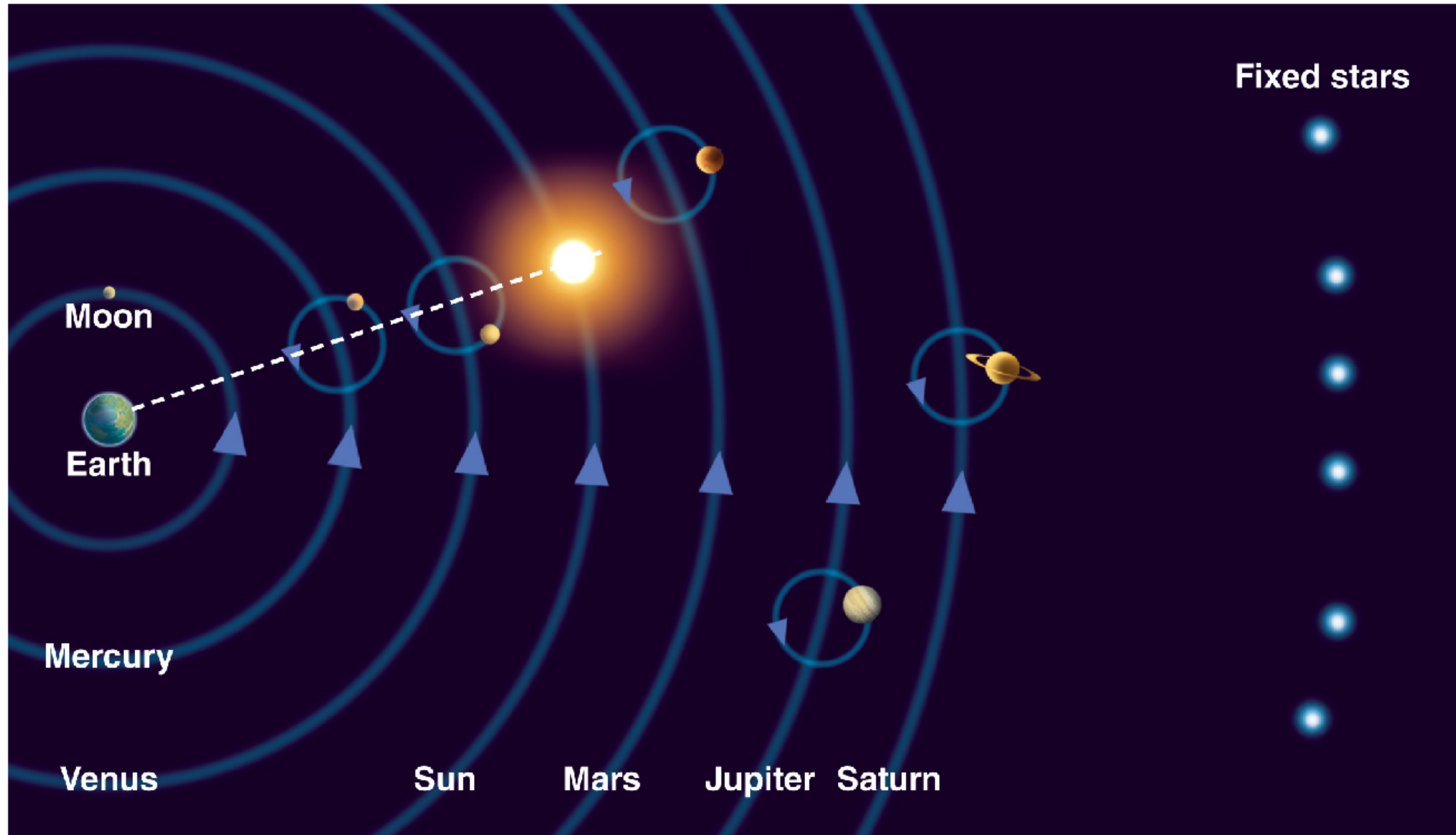

Epicycles

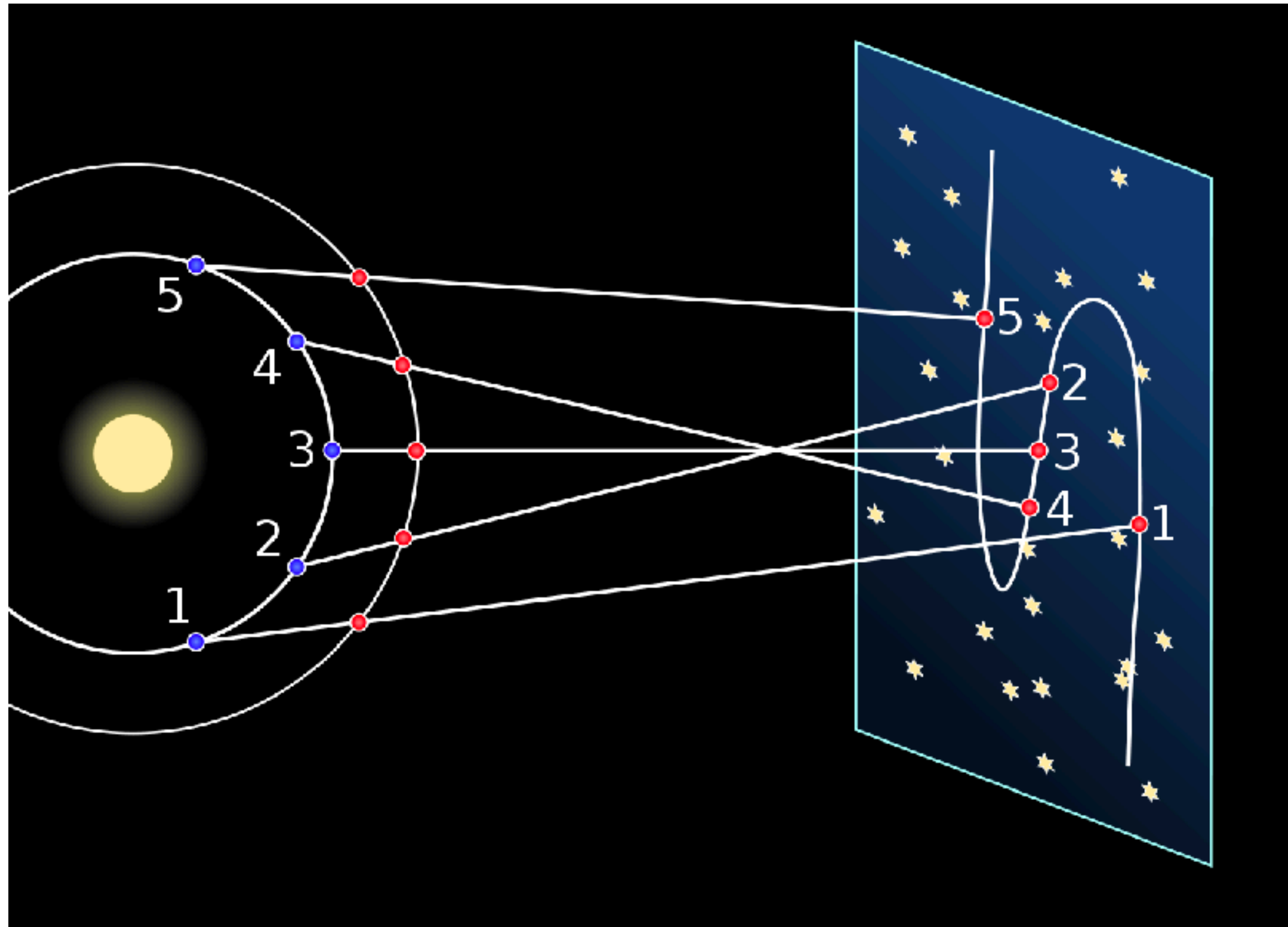

https://en.wikipedia.org/wiki/Apparent_retrograde_motion



Retrograde motion of Mars in 2005.
Credit astrophotographer [Tunc Tezel](#)

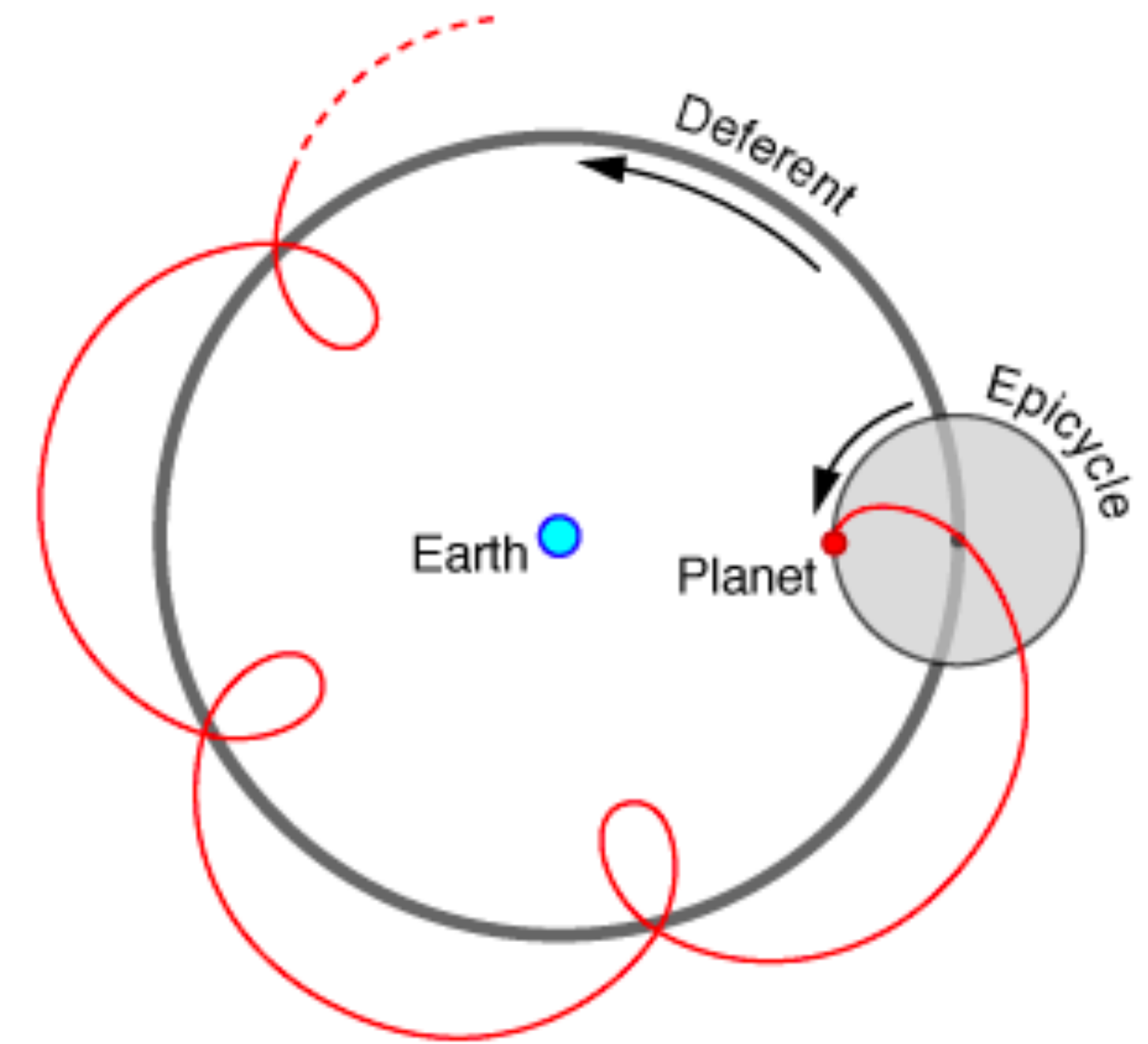

<https://physics.weber.edu/schroeder/ua/BeforeCopernicus.html>

Copernicus politely defies church orthodoxy (really just revisited 1700 year old Greek ideas)

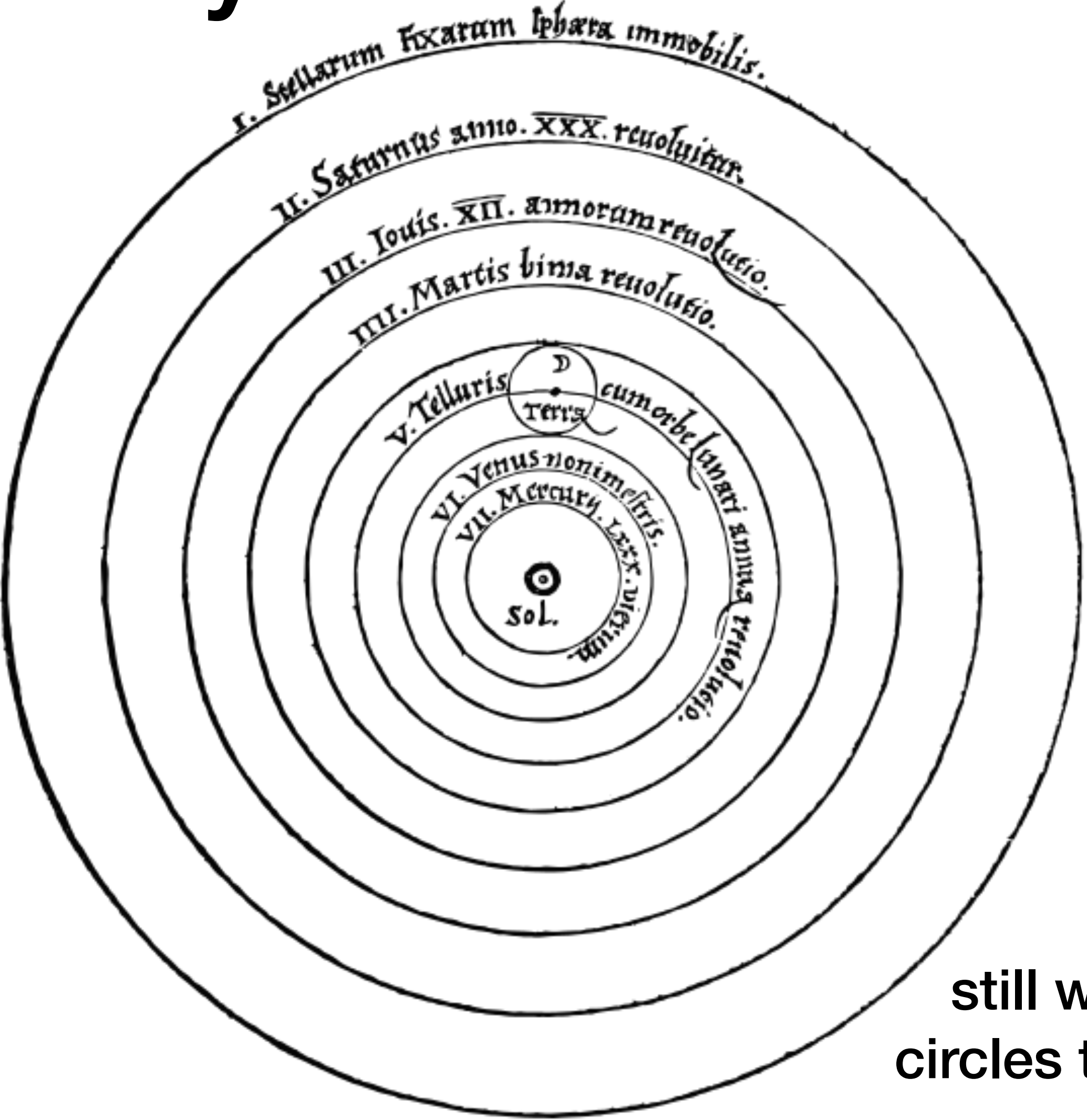
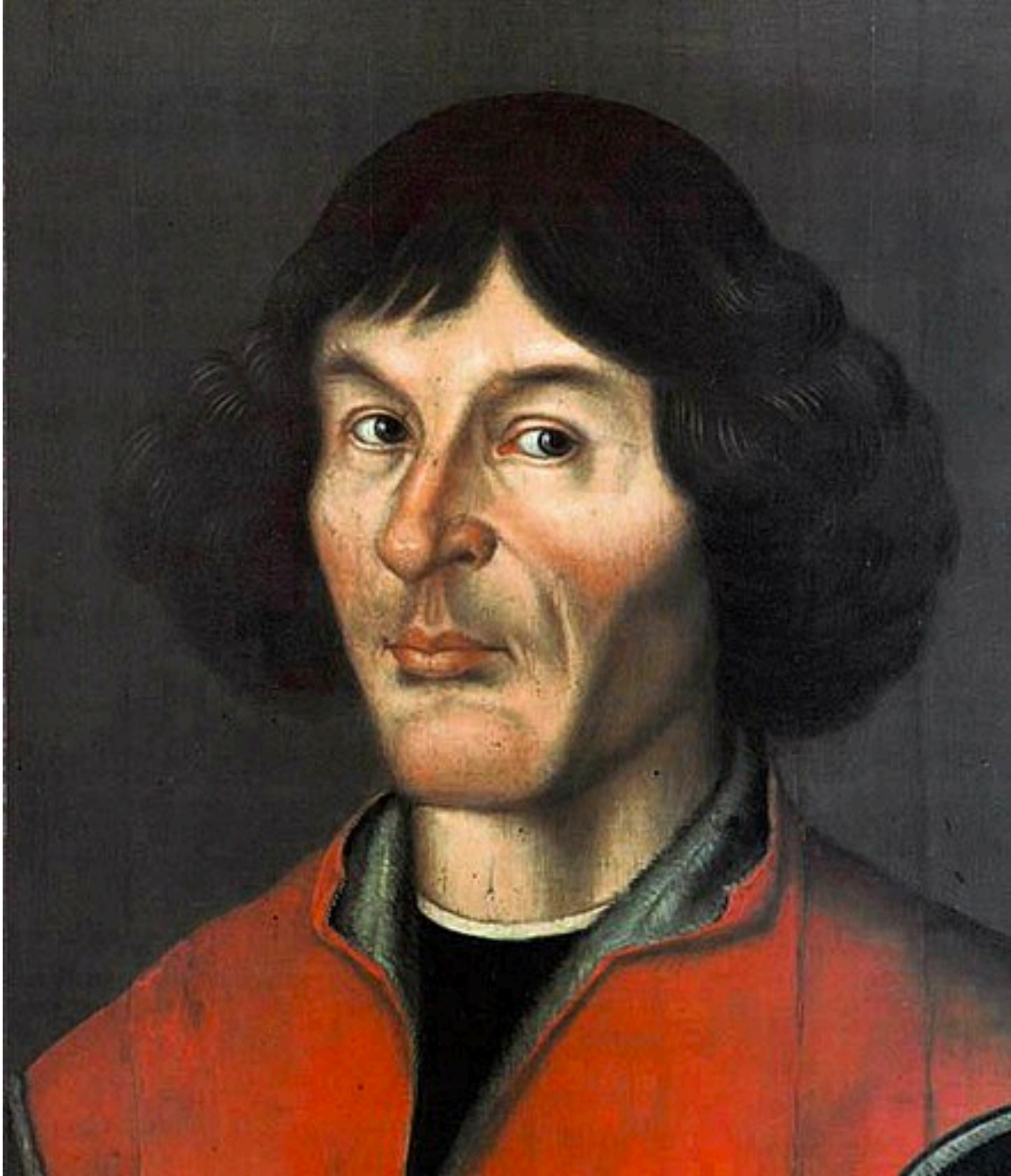

still with the circles though...

Tycho Brahe's dope observations



Made the best astronomical measurements before the age of the telescope

Failed to measure stellar parallaxes — concluded the Earth must be stationary

Built a hybrid model to reconcile the simpler Copernican idea with a stationary Earth

Had a metal nose, died heroically

Kepler's Insight

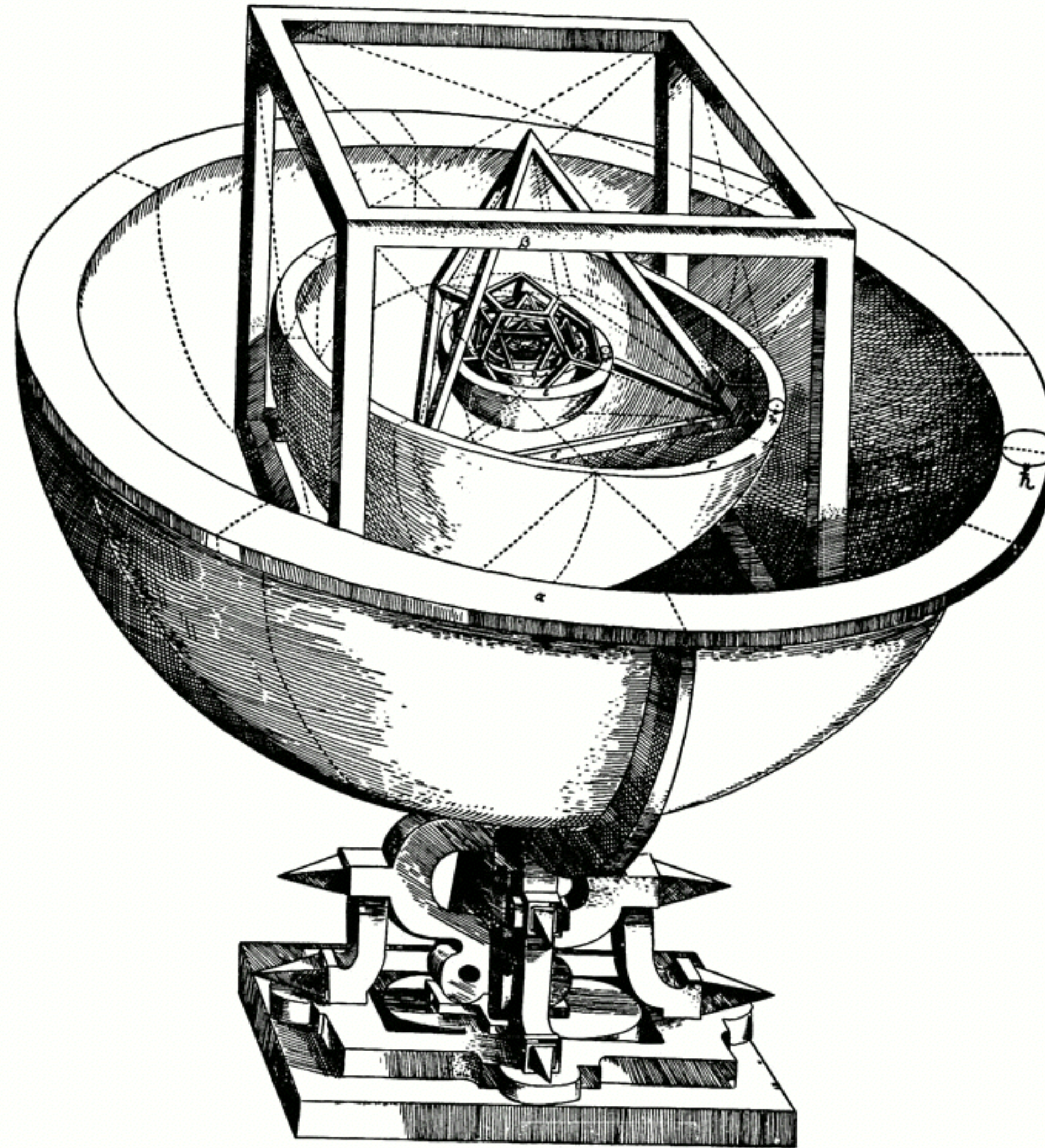

- trusted Tycho's data
- thought Copernicus' Sun-centered model was right
- believed Ptolemy's and Copernicus' assumption that orbits were circular was correct

These assumptions were inconsistent — at least one of them had to be wrong.

Like a good scientist, Kepler trusted the data most and abandoned circles

Kepler's 3 Laws!

1) Planets move around the Sun on elliptical paths, with the Sun at one focus of the ellipse

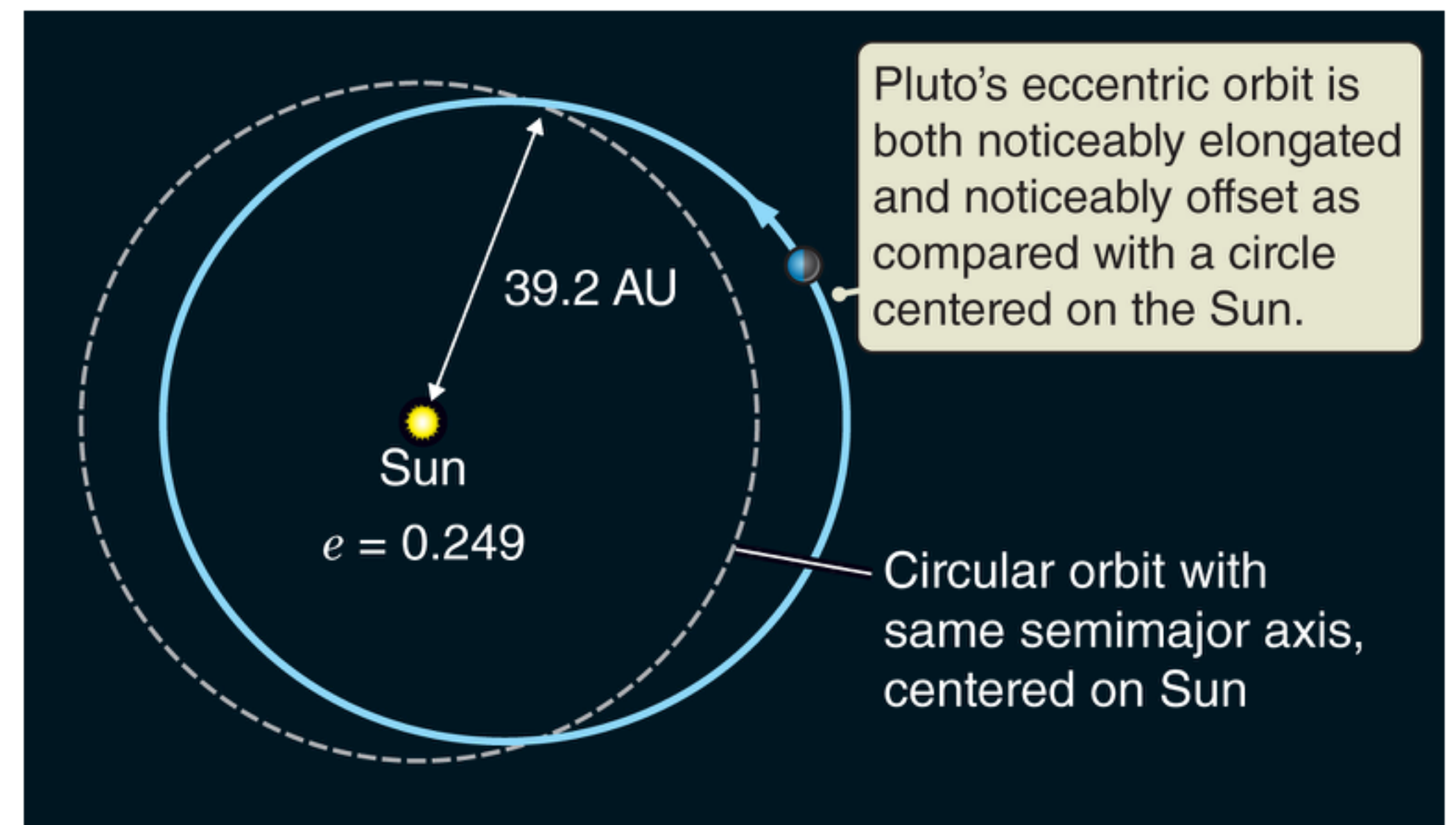
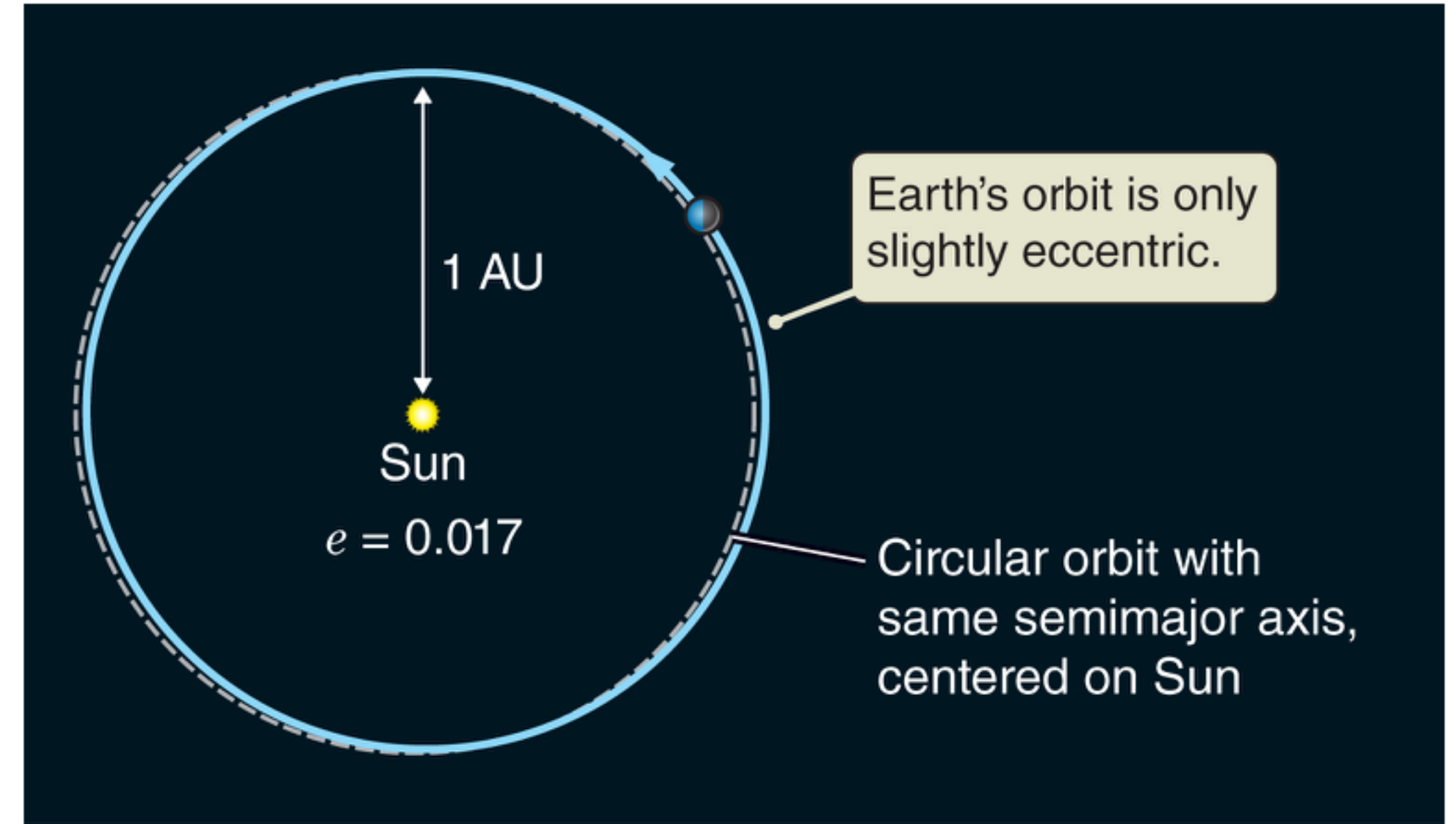
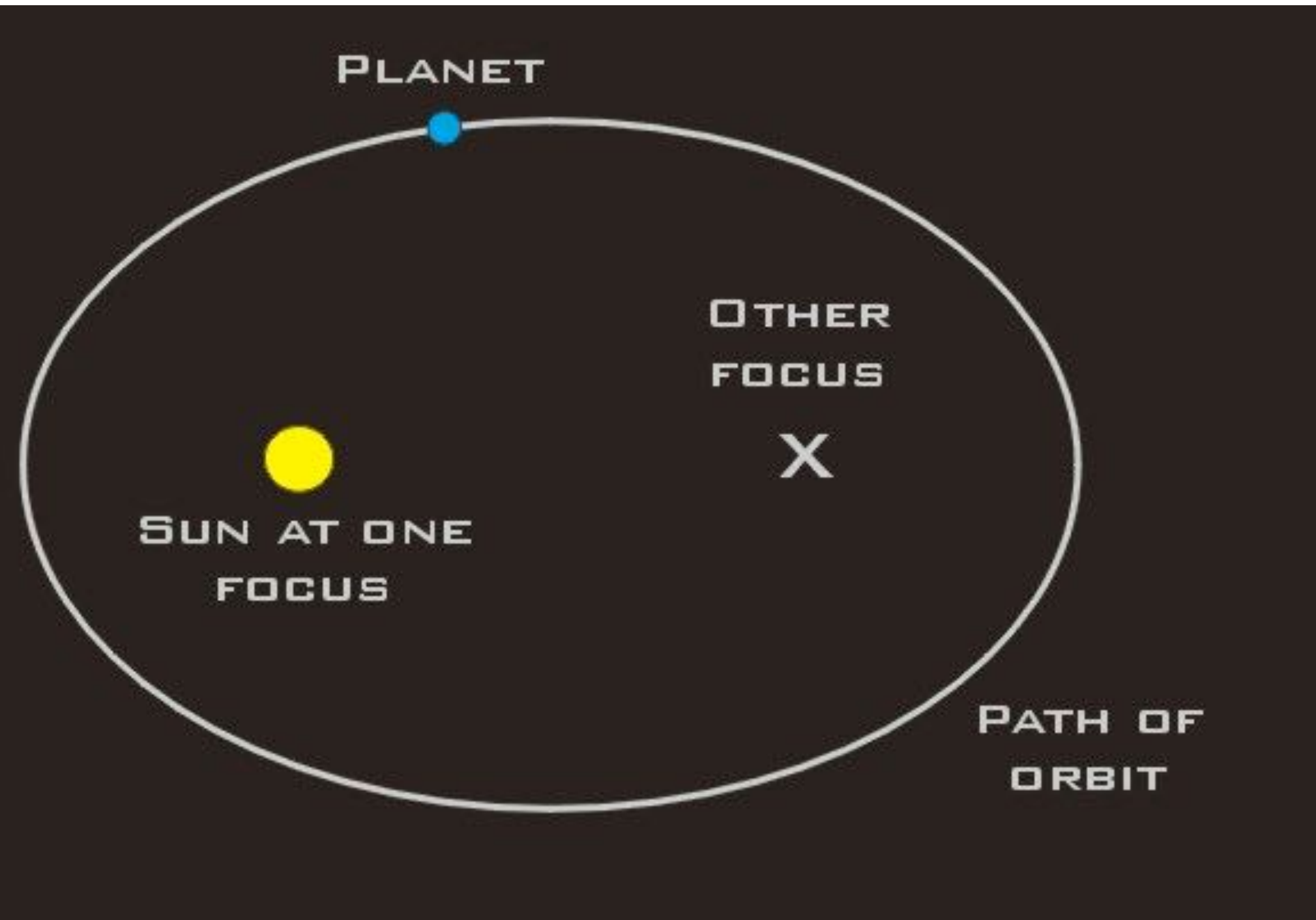

Kepler's 3 Laws!

2) The area of the ellipse traced out by the motion of the planet in a given period of time is always the same: "equal areas in equal times"

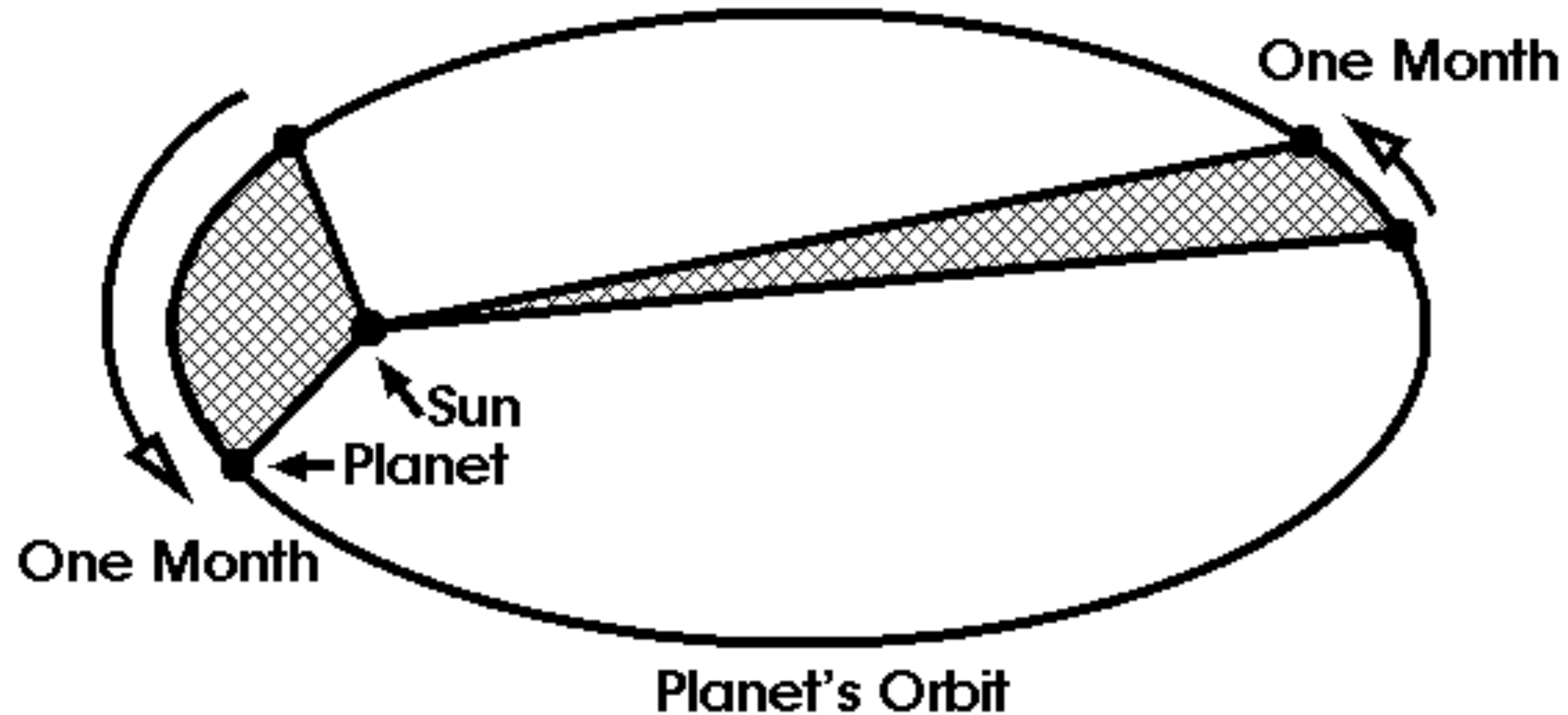

Kepler's 3 Laws!

2) The area of the ellipse traced out by the motion of the planet in a given period of time is always the same: "equal areas in equal times"

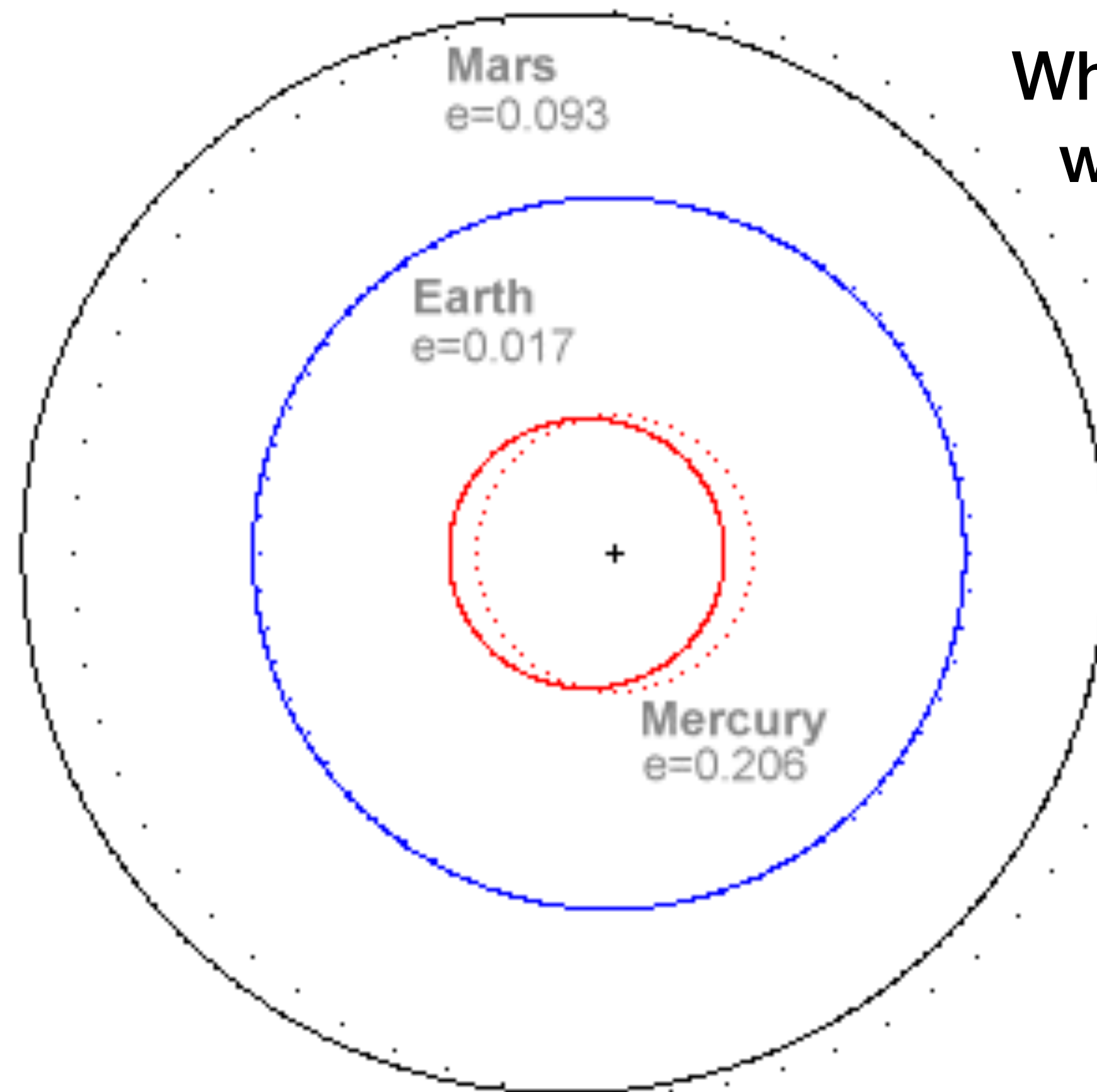
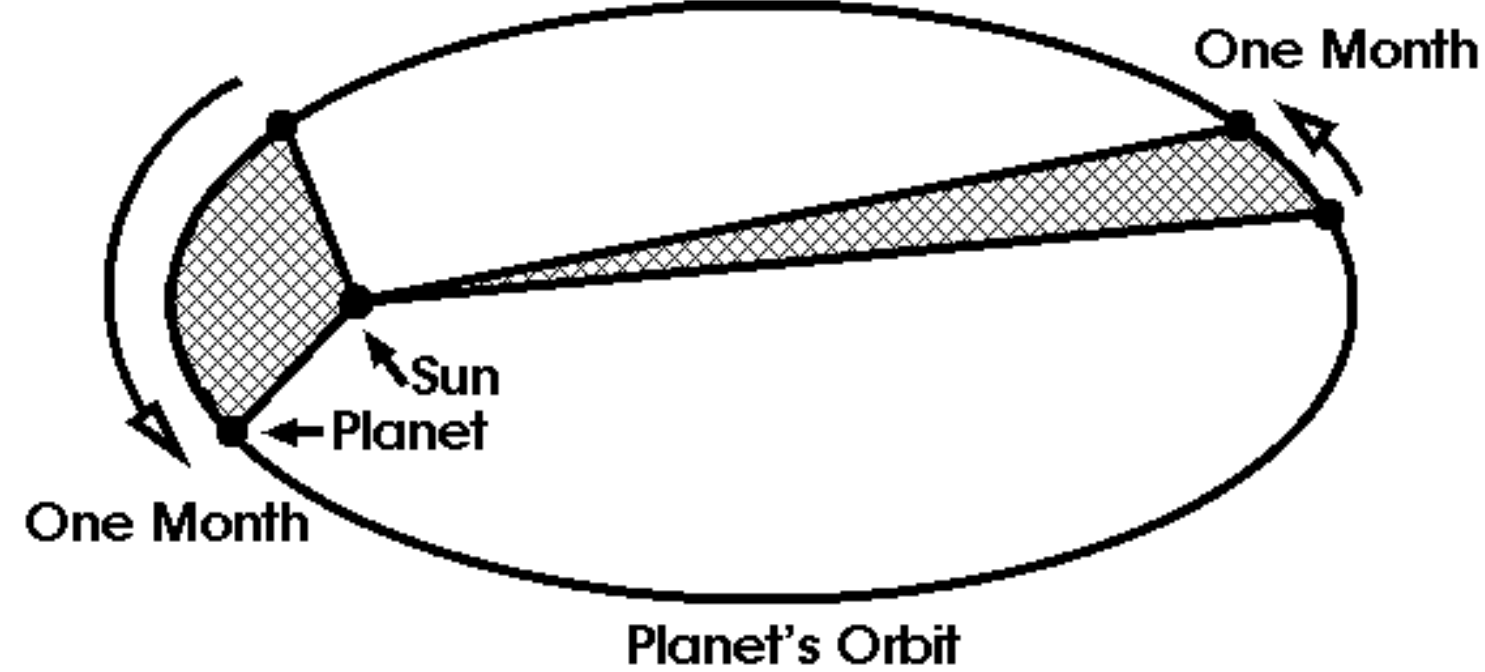

Which of the three planets shown would experience the smallest change in orbital speed?

- A) Mercury
- B) Earth
- C) Mars

Kepler's 3 Laws

3) The farther from the Sun a planet orbits, the slower it moves (in addition to having farther to travel in order to complete a revolution around the Sun).

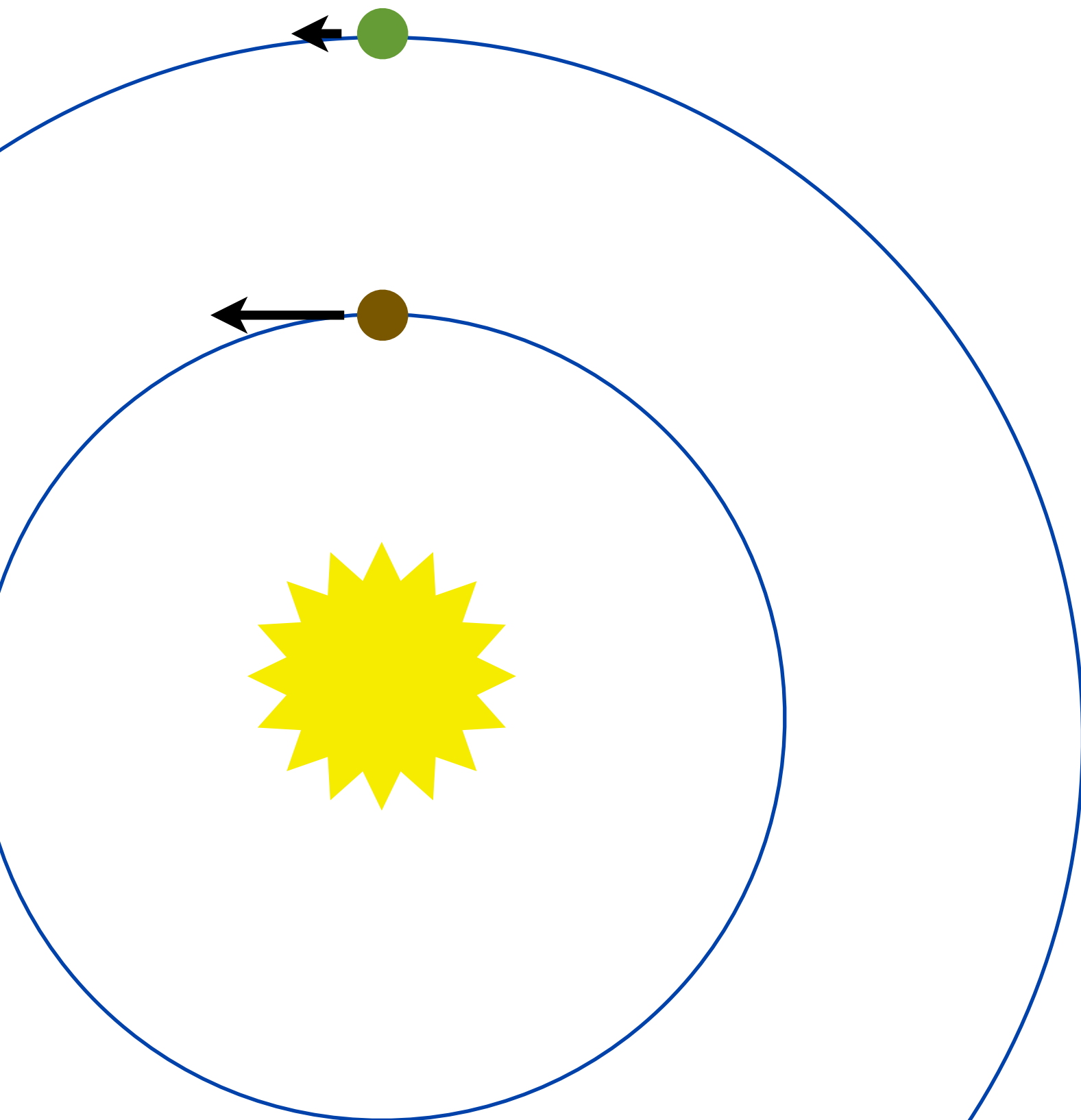

$(\text{Period of Planet [in years]})^2$

=

$(\text{Average Distance of Planet from Star [in AU]})^3$

The earth is one AU from the sun and has a period of one year. If a planet is 2 AU from the sun, its period will be:

$$(P[\text{yr}])^2 = (a[\text{AU}])^3$$

- A) Will be 1/2 as long as Earth's
- B) Will be the same as Earth's
- C) Will be double Earth's period
- D) Will be more than double Earth's period

Which of the following best describes how a planet's mass will affect its orbital period?

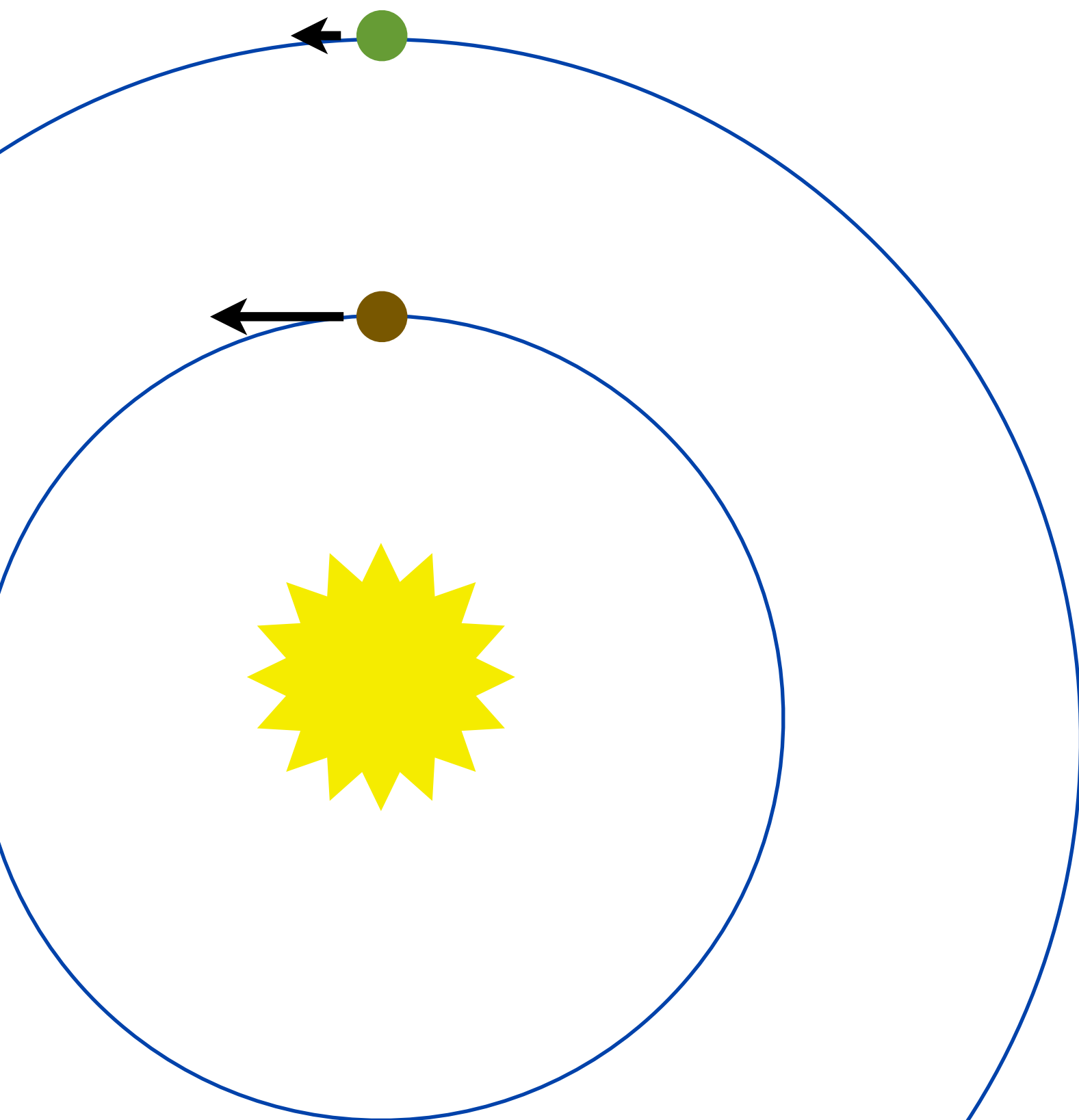

- A) Planets that have small masses have longer orbital periods than planets with large masses
- B) Planets with the same mass will also have the same orbital period
- C) Planets that have large masses have longer orbit periods than planets with small masses
- D) A planet's mass does not affect the orbital period of the planet.

The period of a planet does NOT depend on its mass or the ellipticity of the planet

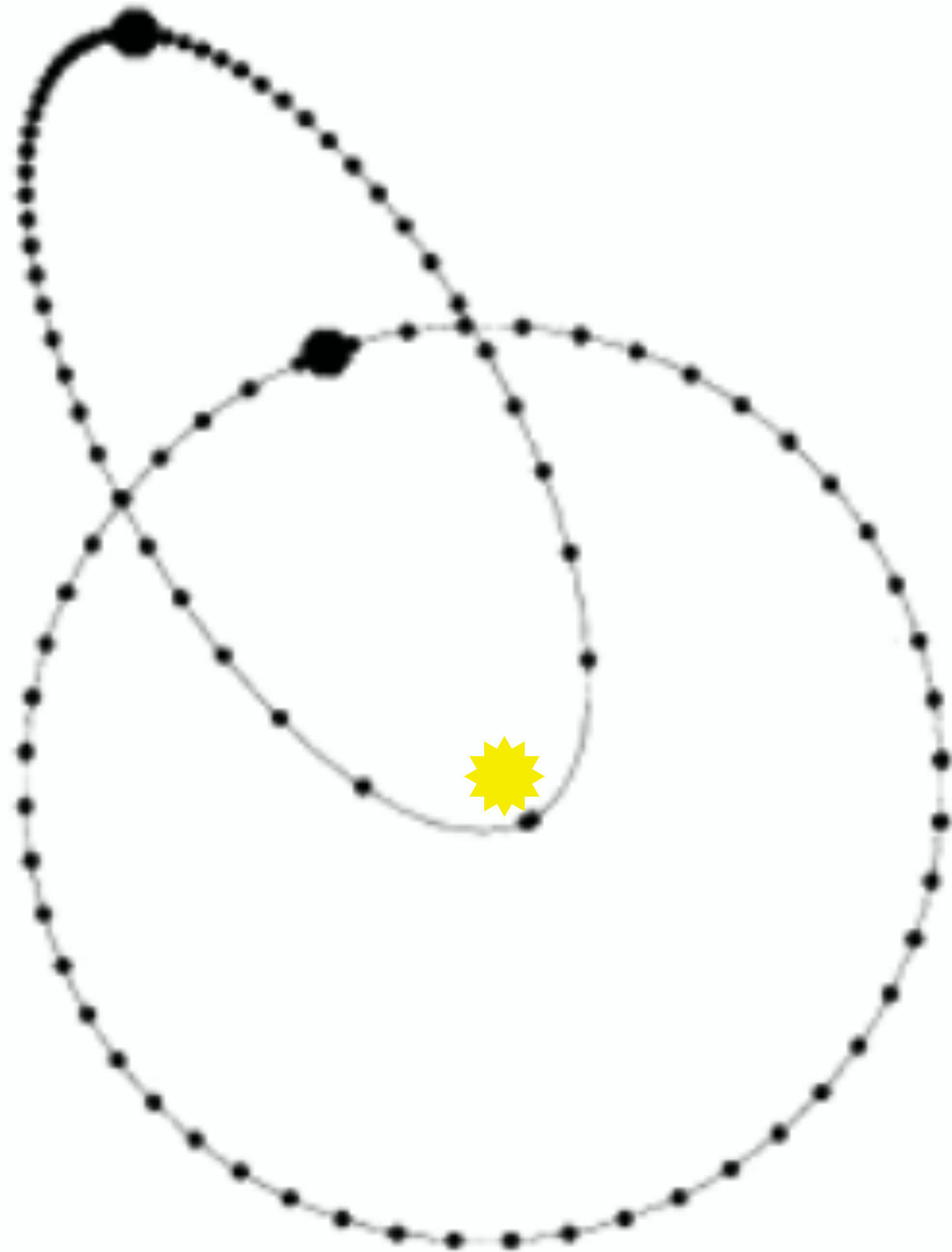

$$(P[\text{yr}])^2 = (a[\text{AU}])^3$$

Ellipses match the data, but WHY ellipses?

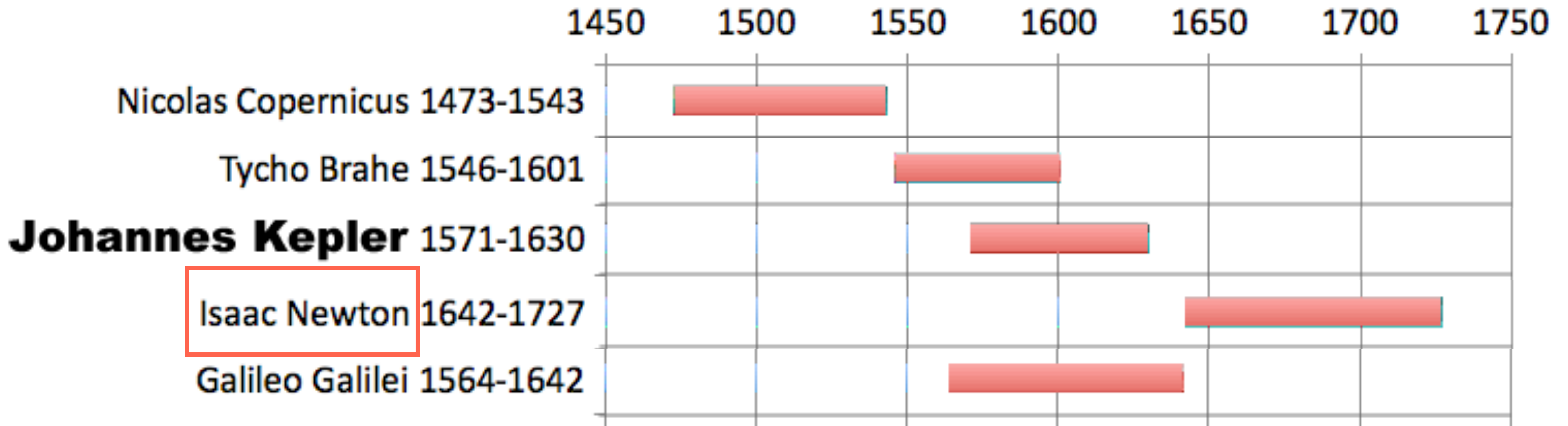

Newton's 3 Laws

- 1) **Law of Inertia: Objects at rest stay at rest, objects in motion stay in motion (Galileo figured this one out)**
- 2) **Motion is changed by unbalanced forces
acceleration = force / mass**
- 3) **Forces always come in pairs and those pairs are always equal in strength but opposite in direction**

Define some terms

position

where something is

velocity

position changing with time, including direction

(speed)

total amount position changes with time

acceleration

velocity changing with time, including direction

$$x, \quad v = \frac{dx}{dt}, \quad a = \frac{dv}{dt} = \frac{d^2x}{dt^2}$$

Newton's 3 Laws - incorporating gravitation

- 1) **Law of Inertia: Objects at rest stay at rest, objects in motion stay in motion (Galileo figured this one out)**
- 2) **Motion is changed by unbalanced forces
acceleration = force / mass**
- 3) **Forces always come in pairs and those pairs are always equal in strength but opposite in direction**

From Apollo 15
David Scott



<http://www.hq.nasa.gov/alsj/a15/video15.html#closeout3>

$$\text{Acceleration} = \frac{\text{Force}}{\text{Mass}}$$

So why do objects of different masses fall at the same speed?

The force of gravity must depend on the mass of the object!

$$\text{Acceleration} = \frac{\overbrace{\text{Something} \times \text{Mass}}^{\text{Force of Gravity}}}{\text{Mass}}$$



Group Activity Time!

**Complete and turn in
at the beginning of
class on Tuesday**

What about Newton's 3rd Law?

Force exerted by object on man Force exerted by man on object

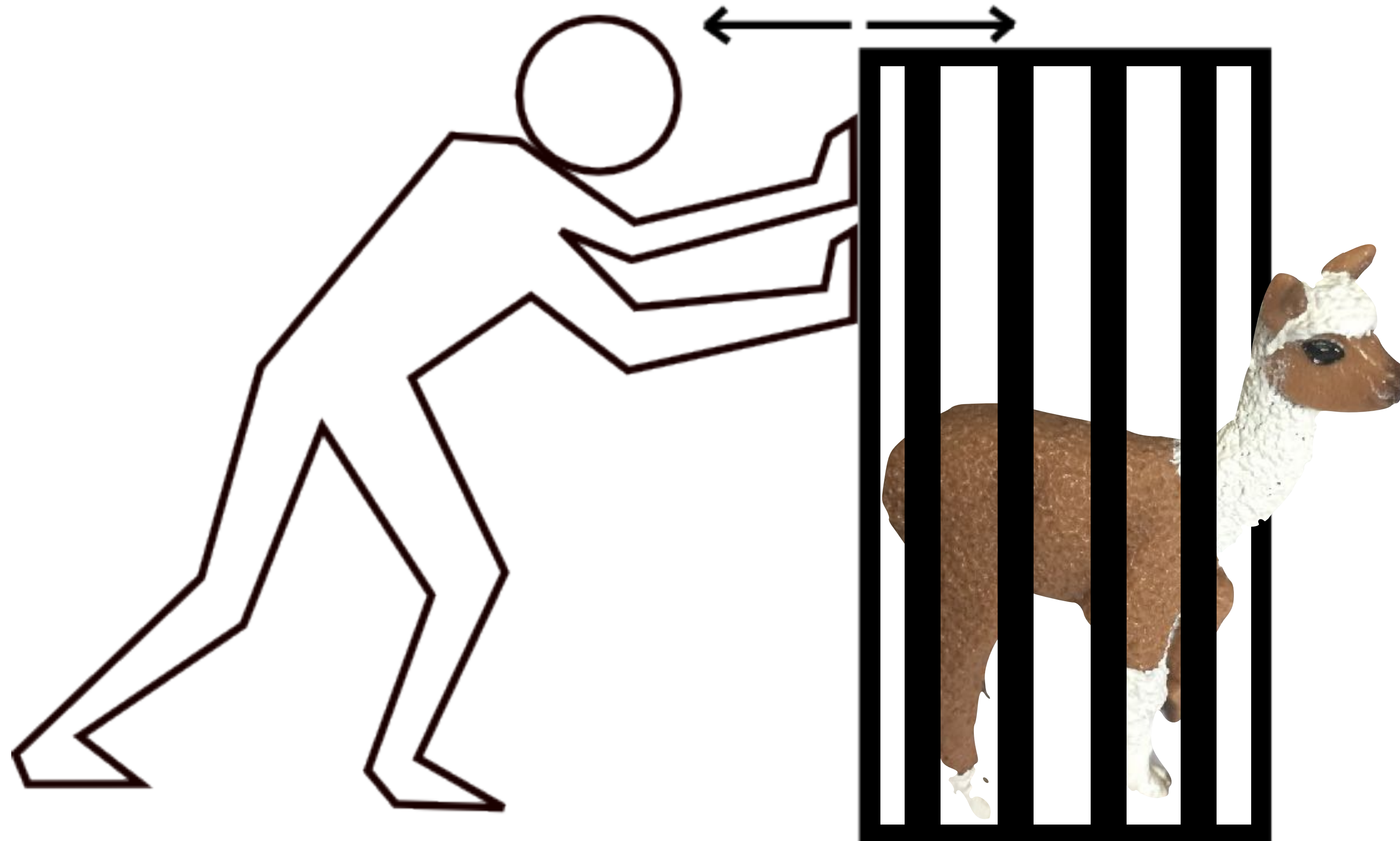

"why should that apple always descend perpendicularly to the ground," thought he to him self: occasion'd by the fall of an apple, as he sat in a contemplative mood: "why should it not go sideways, or upwards? but constantly to the earth's centre? assuredly, the reason is, that the earth draws it. *there must be a drawing power in matter. & the sum of the drawing power in the matter of the earth must be in the earth's centre, not in any side of the earth. therefore does this apple fall perpendicularly, or toward the centre. if matter thus draws matter; it must be in proportion of its quantity. therefore the apple draws the earth, as well as the earth draws the apple.*"

Isaac Newton, quoted
by William Stukeley



If gravity is a property of matter, then any two masses should attract each other

Force of Gravity = Something \times Mass

Force of Gravity =
Something Else \times Mass₁ \times Mass₂

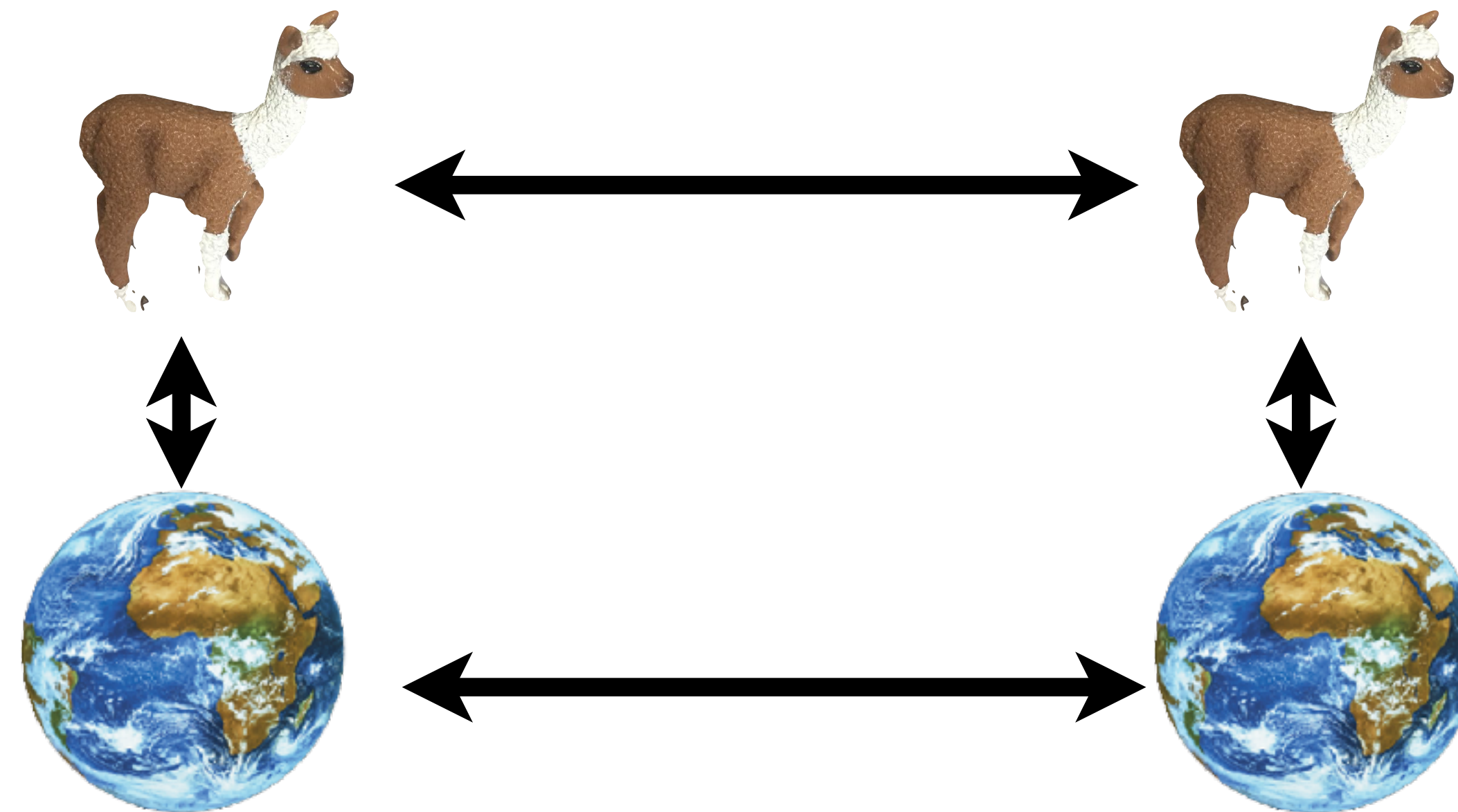

What is that “Something Else”?

Hint: Kepler’s 3rd Law!

$$(P[\text{yr}])^2 = (a[\text{AU}])^3$$

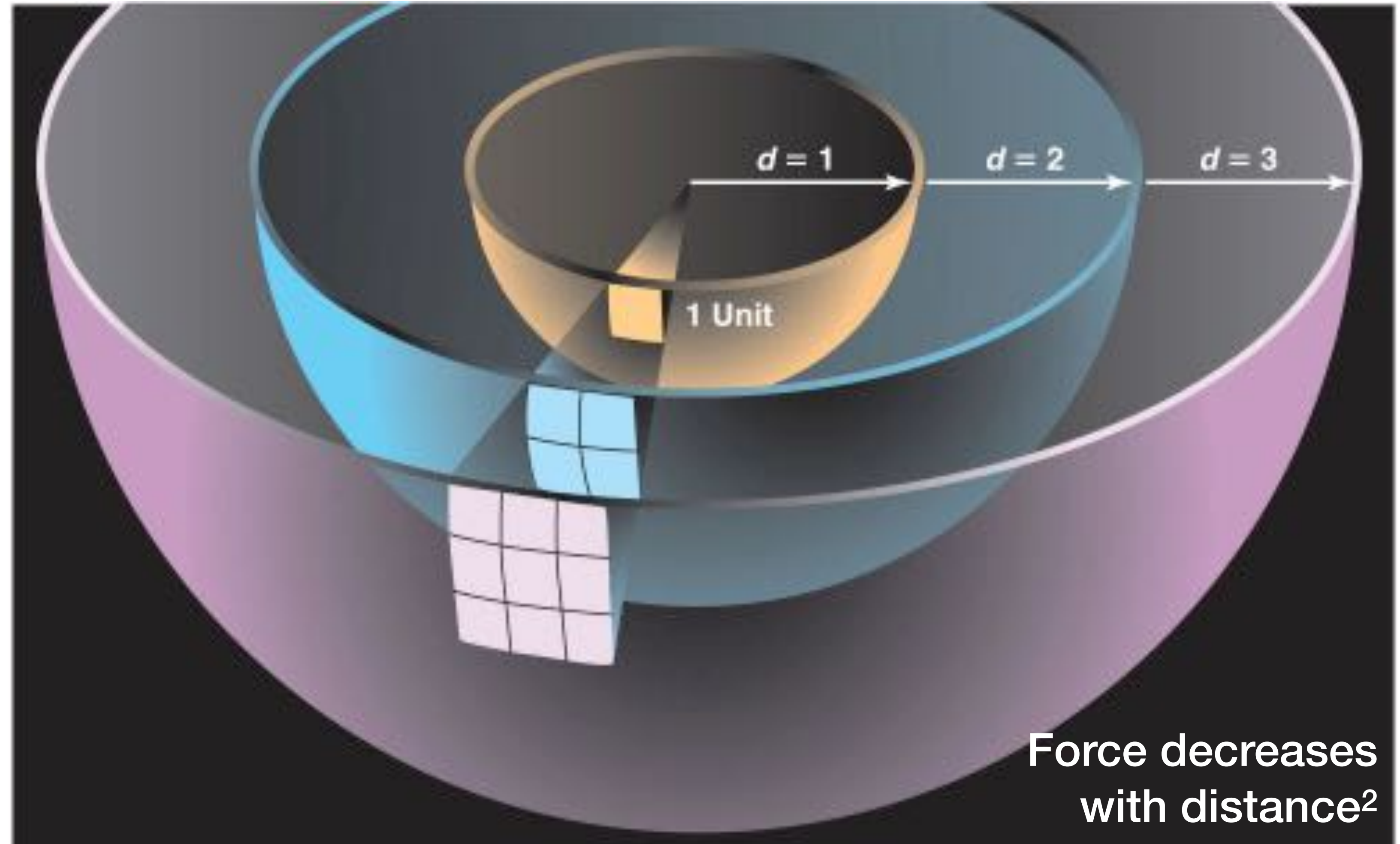
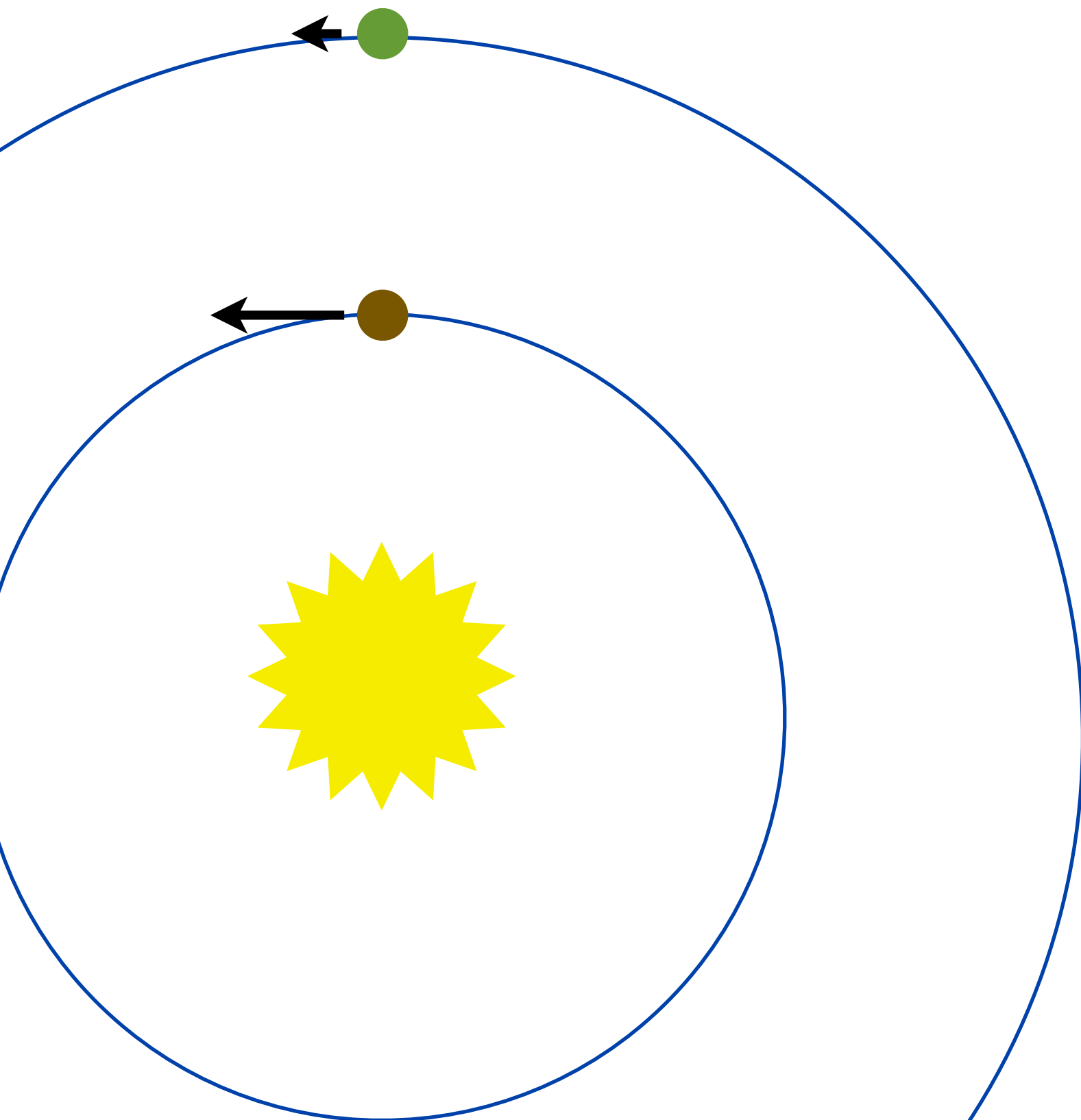

Force decreases
with distance²

© 2007 Thomson Higher Education

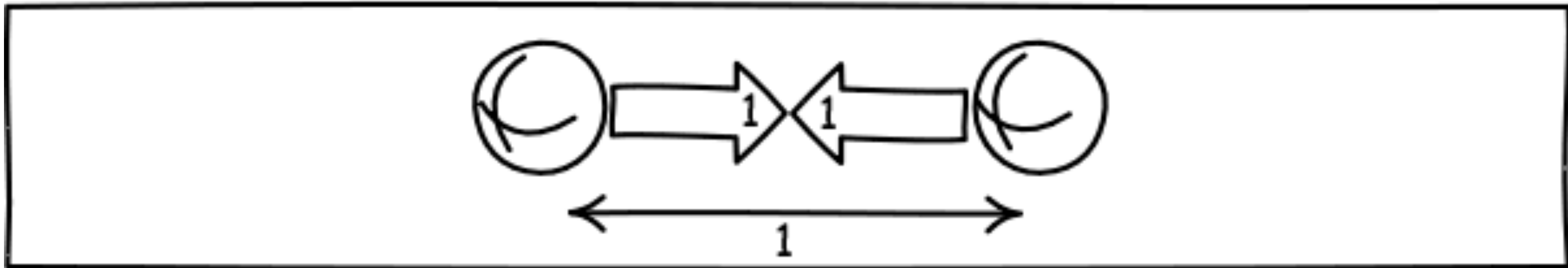
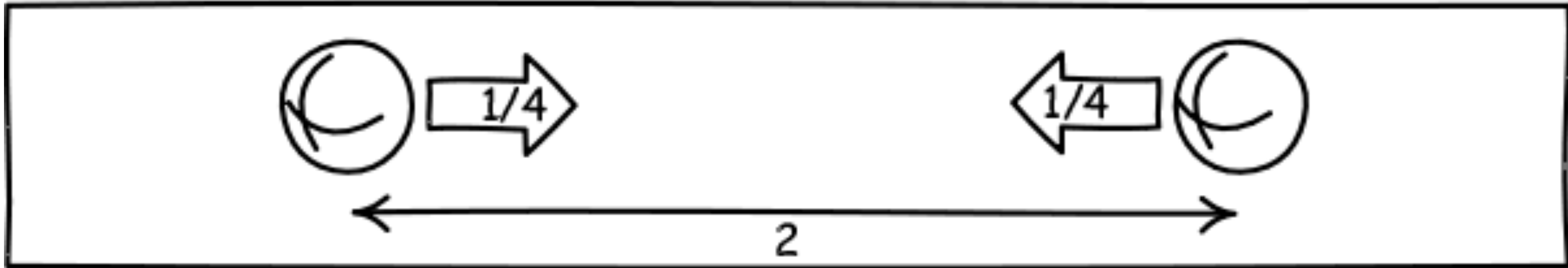
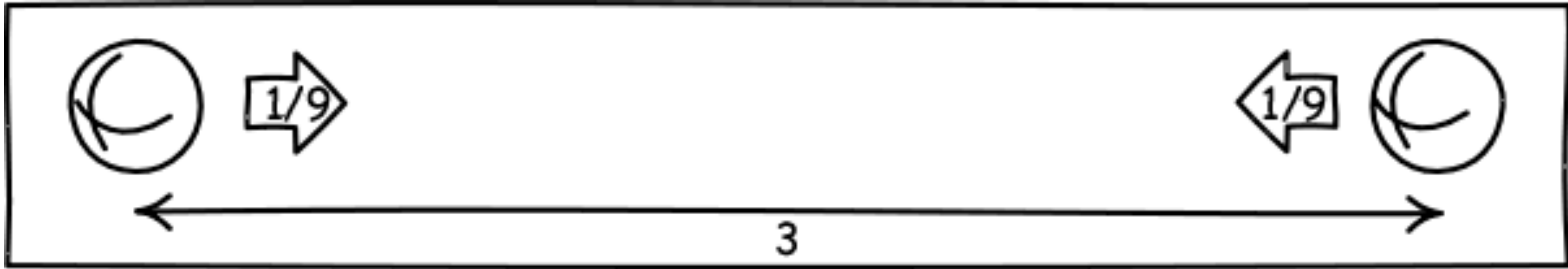

Newton's Universal Law of Gravitation: $F = G \frac{m_1 m_2}{r^2}$

Gravity is an attractive force that acts along the line between two objects.



More mass means more force.

The force is proportional to the product of the two masses.

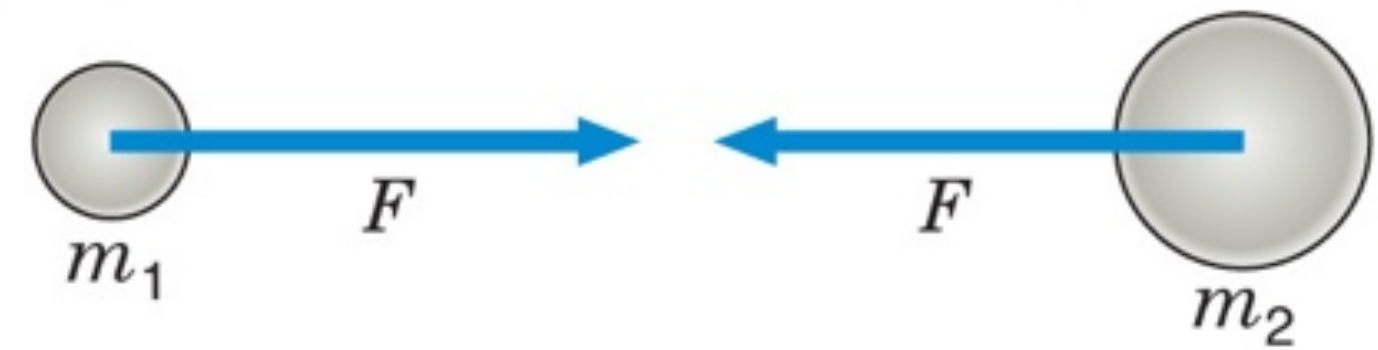

Greater separation means less force.

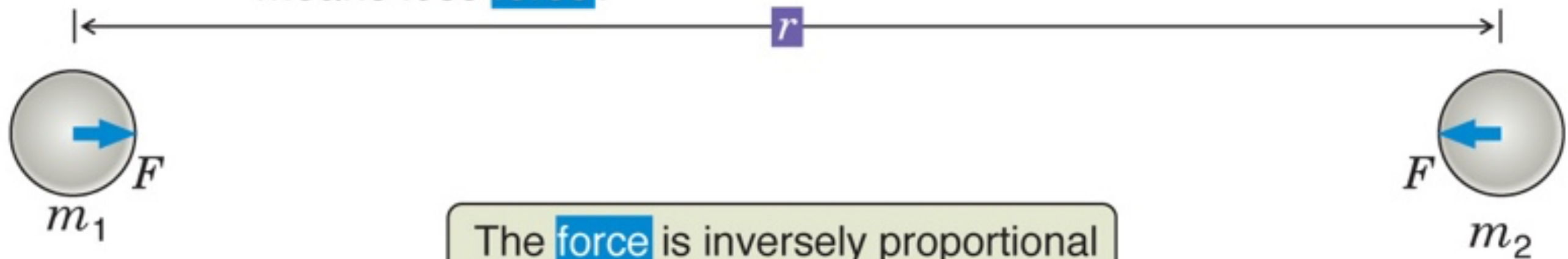

The force is inversely proportional to the square of the distance between the masses.

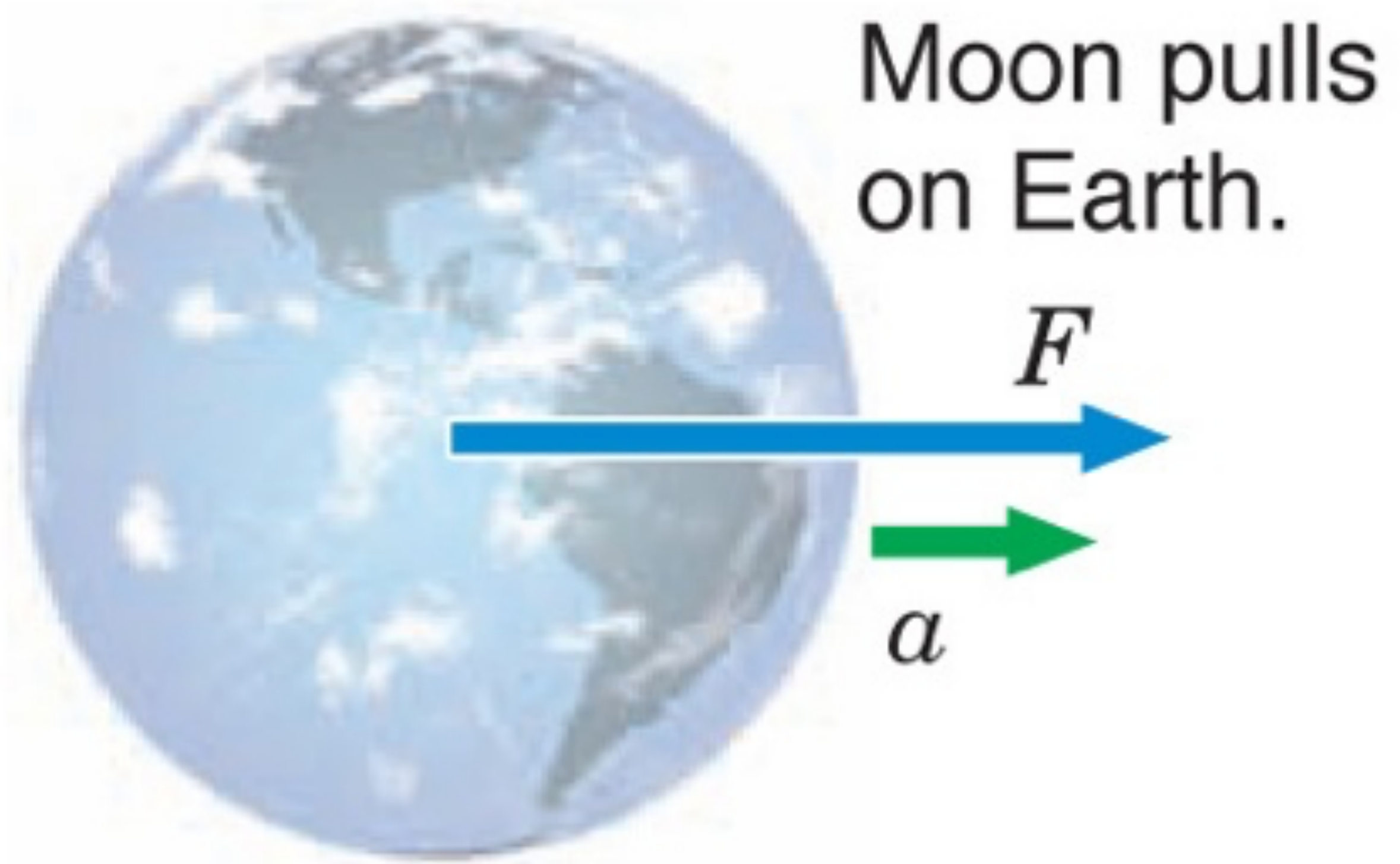

Weight vs. Mass



Earth
Mass: 54 kg
Weight: 120 pounds



Mars
Mass: 54 kg
Weight: 45 pounds

Newton's Universal Law of Gravitation: $F = G \frac{m_1 m_2}{r^2}$

If the mass of the Earth doubled, the gravitational force you'd feel (your weight!) would:

- A) Be smaller by a factor of four
- B) Be smaller by a factor of two
- C) Be larger by a factor of two
- D) Be larger by a factor of four

Newton's Universal Law of Gravitation: $F = G \frac{m_1 m_2}{r^2}$

If the radius of the Earth doubled (but the mass stayed the same), your weight would:

- A) Be smaller by a factor of four
- B) Be smaller by a factor of two
- C) Be larger by a factor of two
- D) Be larger by a factor of four

Gravity and Orbits

(a)

A cannonball travels over the ground as it falls toward Earth.

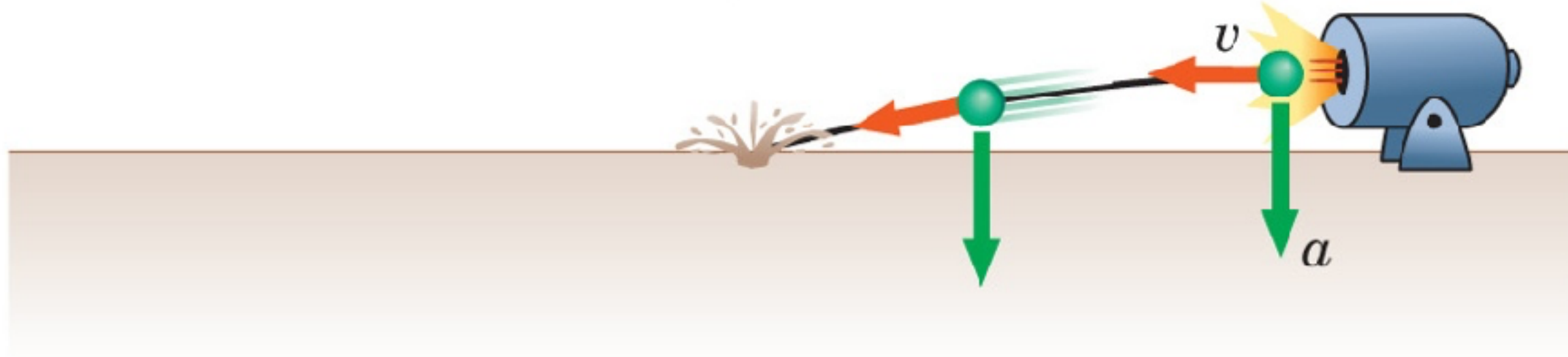

(b)

If fired faster, it travels farther in the time it takes to fall to the ground.



(c)

If fired fast enough, Earth's surface curves out from under the cannonball as it falls.

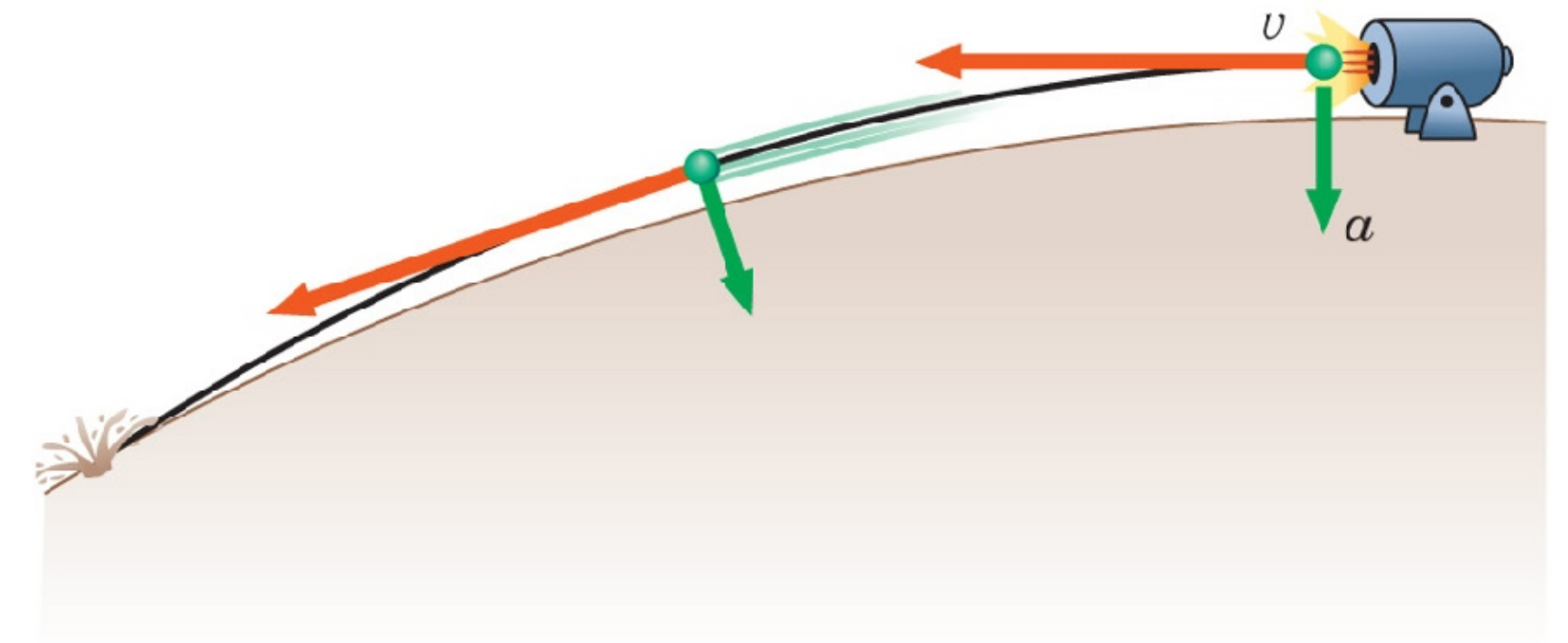

(d)

If fired at the circular velocity and parallel to the ground, the cannonball falls around Earth in a circular orbit.

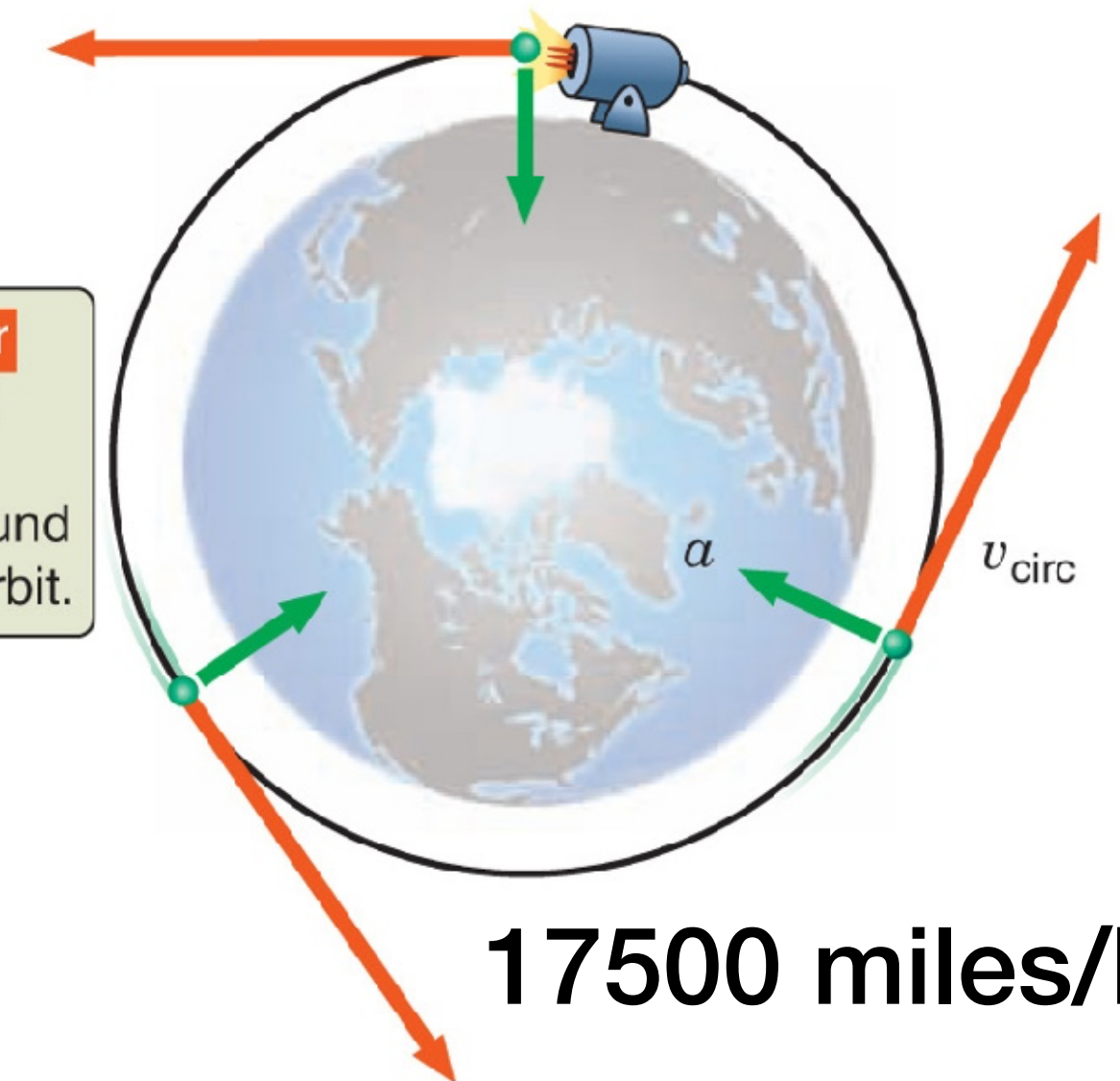

17500 miles/hr



<http://www.youtube.com/watch?v=rWT-DJNSxtg>

Why is it so hard to make a burrito in outer space?

- A) Because the burrito and astronaut are falling at the same speed
- B) Because the astronauts are above Earth's atmosphere
- C) Because astronauts are outside the gravitational influence of Earth
- D) Because the astronauts are in a vacuum

Not zero gravity. All objects are in free fall.

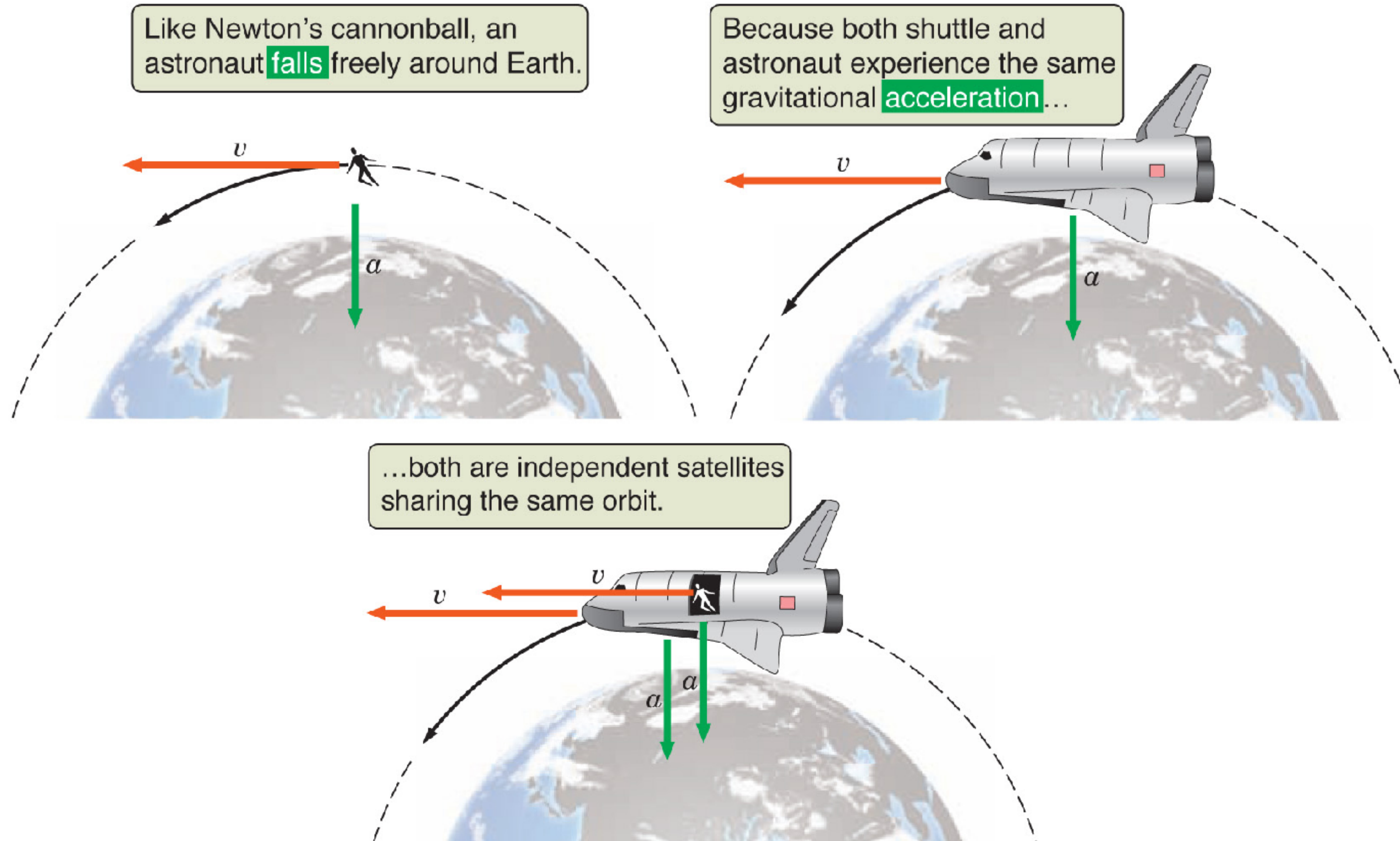

If there is a satellite in a circular orbit half way between Earth and the Moon, will that satellite's circular velocity be:

- A) Slower than the moon**
- B) The same speed as the moon's average speed**
- C) Faster than the moon**

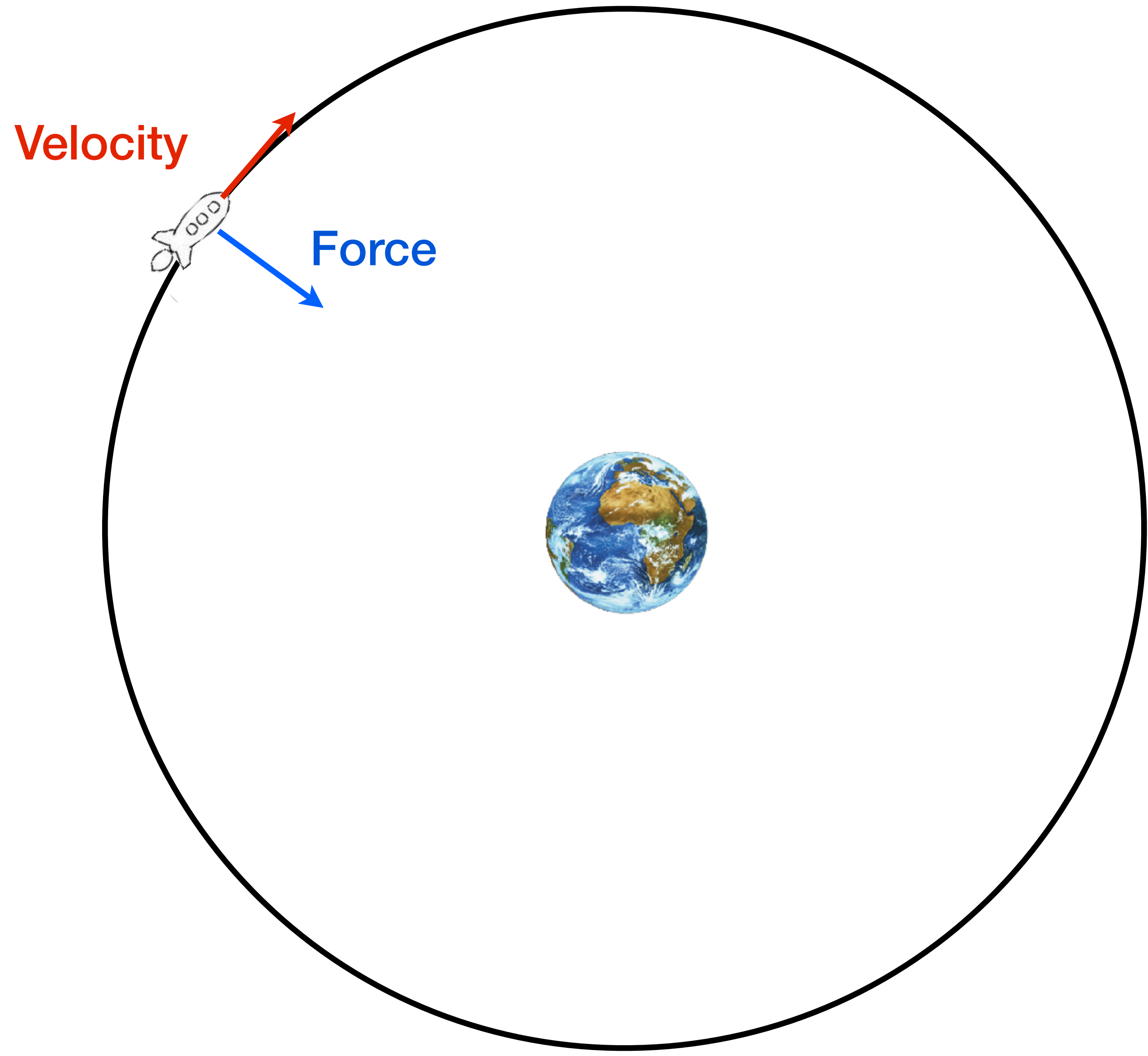

What will happen if I launch a rocket into a circular orbit and then it turns on its engines to accelerate itself in the direction its going?

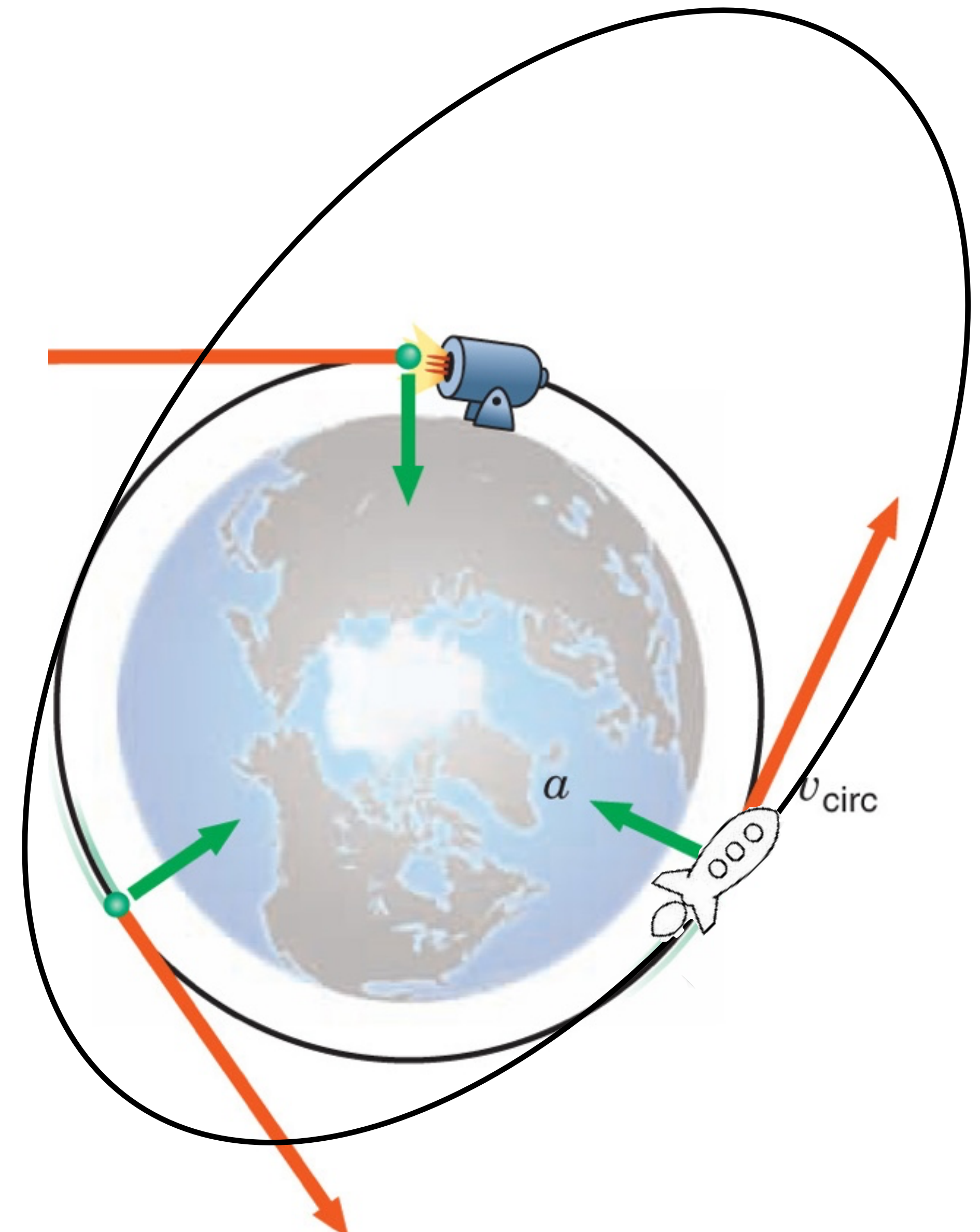

Thusly, Kepler's Laws are explained!

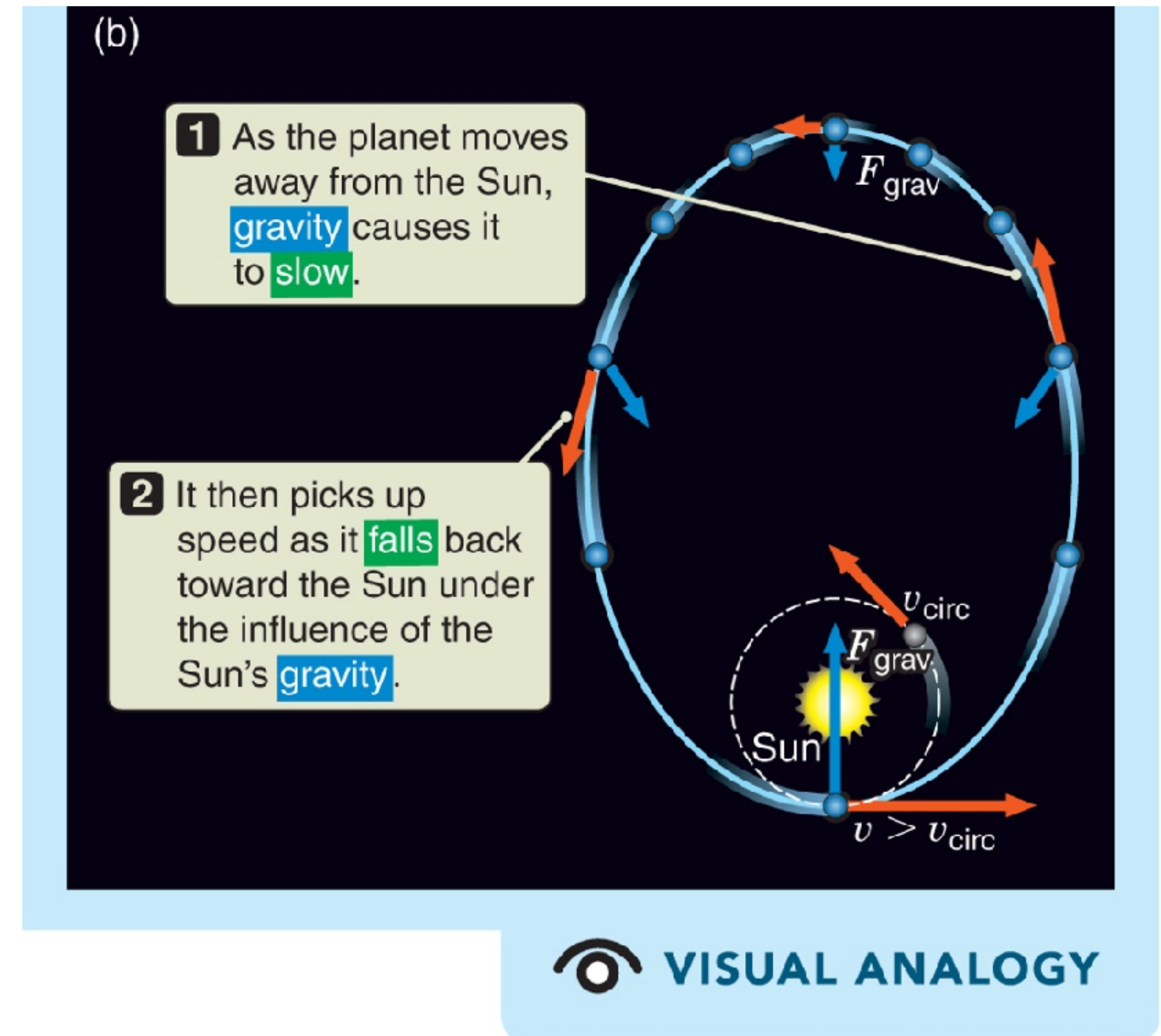
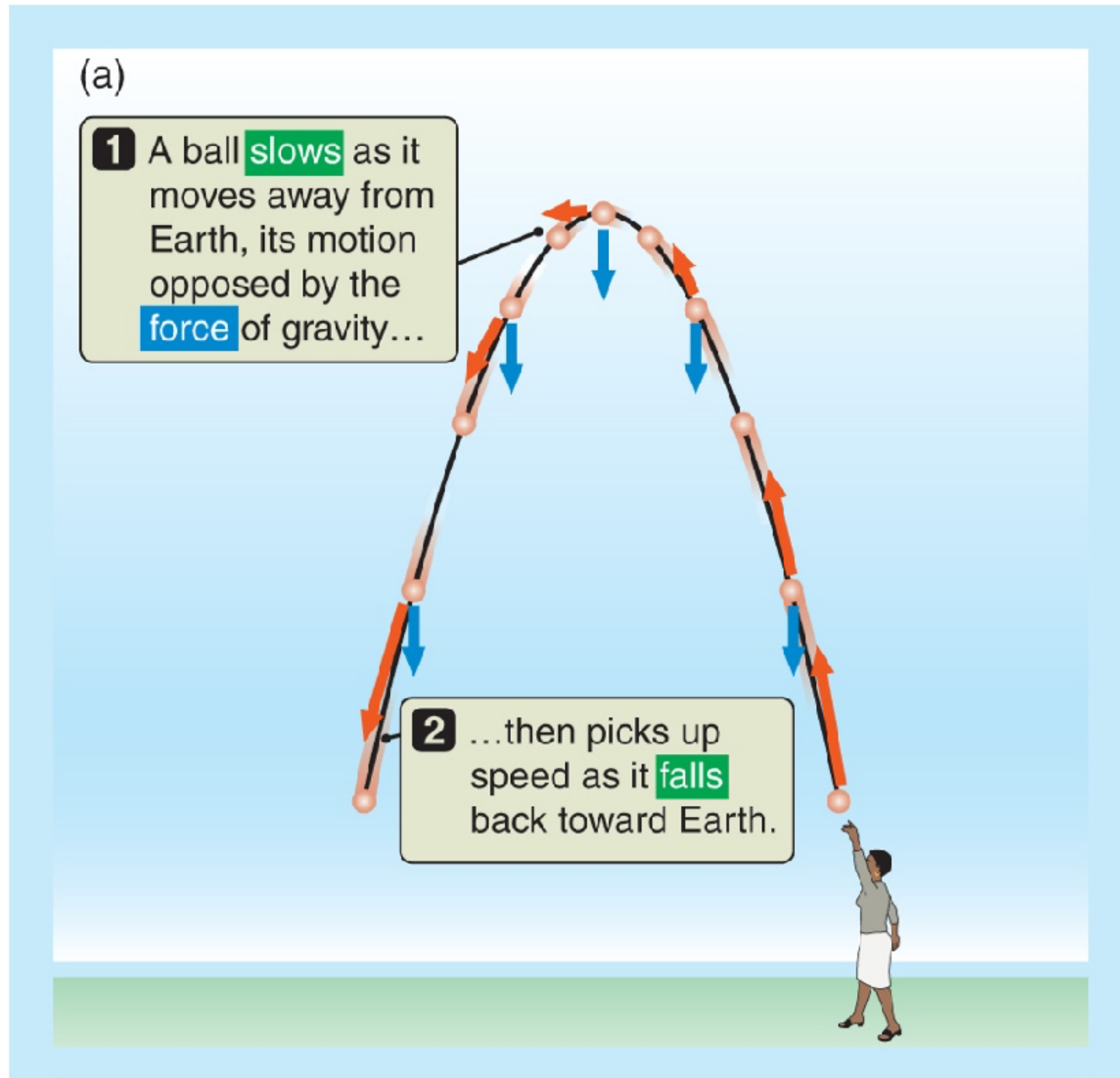

Escape Velocity

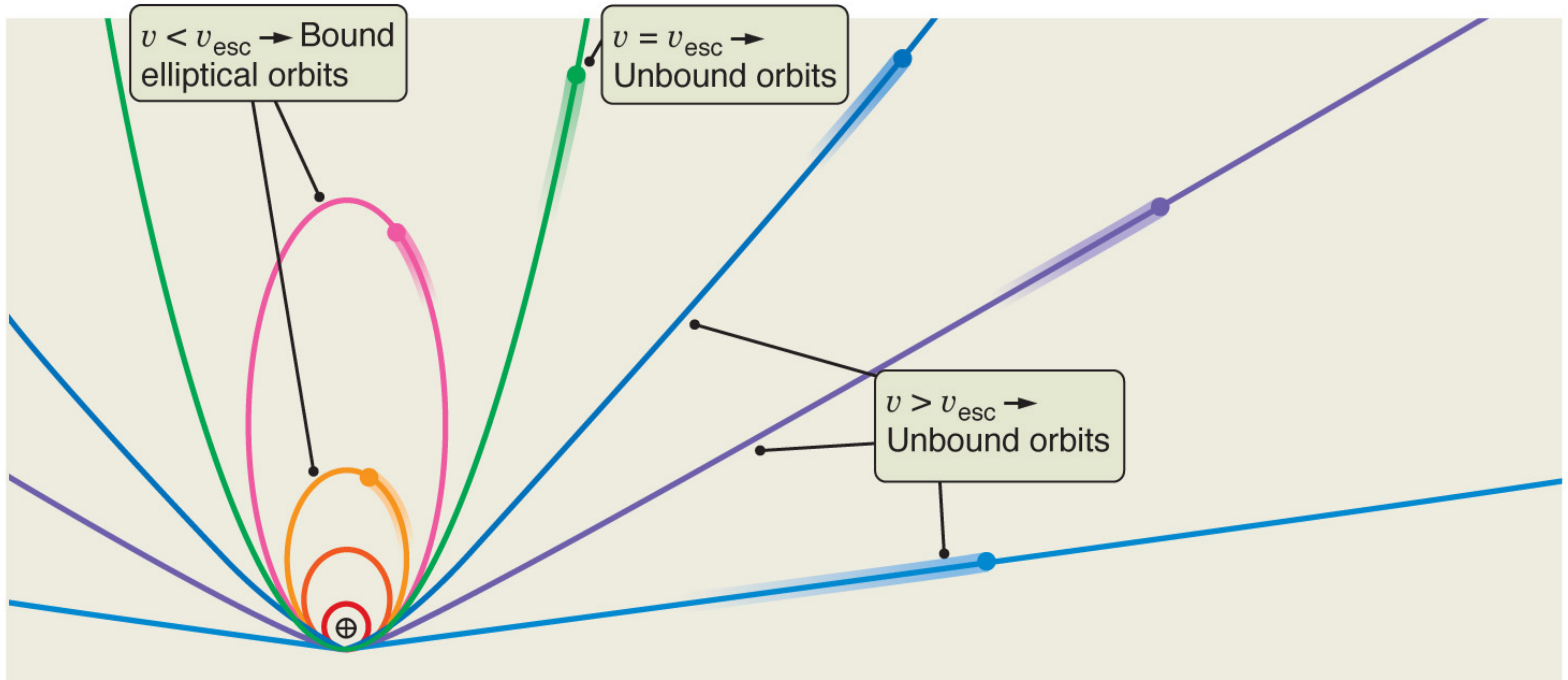

For Earth $v_{esc} \sim 25,000$ miles/hour

